

SUPEROFFER
2022



EN



POWER ASSIST SCREWDRIVER

62/2022
valid till 31/03/2023

Index by item

New item

0			280 LTSTX/S8	PAGE 41	493 B	PAGE 73	519/280T	PAGE 28	519 RS8/3V	PAGE 8	922 B1	PAGE 95
001 RV	PAGE 32	280 TK/SE6	PAGE 42	493 C	PAGE 73	519/285A1	PAGE 28	519 RSC4/3V	PAGE 9	922 B2	PAGE 95	
001 TRV	PAGE 32	280 T/SE7	PAGE 42	495 098HYB	PAGE 77	519/285B2	PAGE 28	519 RSC4/4V	PAGE 9	922 BL1	PAGE 95	
002 JMA	PAGE 30	280 TTS/SE6	PAGE 42	495 MAA	PAGE 26	519/285KA1	PAGE 28	519 RSC4/5V	PAGE 9	922 BP1	PAGE 95	
002 JMP	PAGE 31	280 TTX/SE8	PAGE 42	495 MB	PAGE 26	519/294	PAGE 28	600			926 A	PAGE 67
002 JTMA	PAGE 30	280 XLTS/S9	PAGE 41	495 MC	PAGE 26	519/322H	PAGE 28	601 1/2" J22	PAGE 56	928 AC1 1/2"	PAGE 92	
007/1V	PAGE 34	282 S10	PAGE 72	495 PA	PAGE 27	519/322STX	PAGE 28	601 1/4-1/2" J82	PAGE 57	928 D1 3/4"	PAGE 93	
007 FTSV	PAGE 35	285 DS8	PAGE 48	495 PM	PAGE 27	519/324H	PAGE 28	601 1/4-1/2" J100	PAGE 57	929 PC1 1/2"	PAGE 90	
007 MLV	PAGE 65	285 J/B16	PAGE 57	500			519/324TX	PAGE 28	601 1/4-1/2" JTX16	PAGE 56	929 PC1/C12	PAGE 91
007 MV	PAGE 65	285 KA/DS8	PAGE 49	504 S	PAGE 15	519/366	PAGE 28	601 1/4" J34	PAGE 56	939 C1	PAGE 94	
007 RV	PAGE 35	285 KA/DS12	PAGE 49	506 BA	PAGE 23	519/382F	PAGE 28	604 1/2" ED	PAGE 53	942 PC3 1/2"	PAGE 90	
007 SV	PAGE 35	285 KB/SR8	PAGE 50	506 BAC/2000	PAGE 23	519/613AEA	PAGE 28	605 1/4" ED	PAGE 53	942 PC3/C7	PAGE 91	
007 TV	PAGE 35	285 KF/DS8	PAGE 50	506 BL	PAGE 23	519/613BEA	PAGE 28	606 1/2" EA	PAGE 52	942 PD1 3/4"	PAGE 93	
007 TXV	PAGE 34	285 L/SE4	PAGE 50	506 BLC/2000	PAGE 23	519/613CEA	PAGE 28	606 1/4" EA	PAGE 52	942 PE1 1"	PAGE 93	
007 V	PAGE 34	285 SE26	PAGE 48	516 AC1	PAGE 13	519/990A1	PAGE 28	606 1/4" SK	PAGE 54	943 PC1 1/2"	PAGE 90	
074 A	PAGE 65	294 AC	PAGE 47	516 AC2	PAGE 13	519 ACT1	PAGE 7	608 1/4" EAK	PAGE 55	943 PC1/C12	PAGE 91	
076 G	PAGE 65	294 AD	PAGE 47	516 AC3	PAGE 13	519 ACT2	PAGE 7	609 1/4" EB	PAGE 54	943 PC2 1/2"	PAGE 92	
085 EX/SE3	PAGE 44	294 AG	PAGE 47	516 AC4	PAGE 13	519 ACT3	PAGE 7	610 1/4" EFK	PAGE 54	988 D/S3	PAGE 70	
091 D/SH5	PAGE 39	299 SE4	PAGE 51	516 AC5	PAGE 13	519 ACT4	PAGE 7	612 3/4" B	PAGE 55	988 E/S10	PAGE 70	
091 SH5	PAGE 39	300			516 AC6	PAGE 13	519 ACT5	PAGE 7	612 3/4" EB	PAGE 55	988 G/S12	PAGE 70
091 SH8	PAGE 39	305 N	PAGE 68	516 AC7	PAGE 13	519 ACT6	PAGE 7	618 MF1	PAGE 72	988 LA/S14	PAGE 70	
098 3/8" HYB8	PAGE 77	307 A/S7	PAGE 68	516 AC8	PAGE 13	519 ACT7	PAGE 7	618 MF2	PAGE 72	988 MA/S19	PAGE 70	
099 BG	PAGE 76	314 C	PAGE 68	516 AC9	PAGE 13	519 ACT8	PAGE 7	640 A	PAGE 33	988 MA/S25	PAGE 70	
099 FS	PAGE 76	317 K	PAGE 68	516 AC10	PAGE 15	519 ACT9	PAGE 7	641 T	PAGE 32	995 A	PAGE 67	
099 G	PAGE 76	322 SH7	PAGE 39	516 SA/C1	PAGE 20	519 ACT10	PAGE 7	646/5LV	PAGE 33	995 AF	PAGE 67	
099 H	PAGE 76	322 SH10	PAGE 39	516 SA/C2	PAGE 20	519 ACT11	PAGE 7	664 B/S7	PAGE 40	995 CA	PAGE 66	
099 L	PAGE 76	324 L/SH5	PAGE 37	516 SA/C3	PAGE 21	519 ACT12	PAGE 7	664 S25	PAGE 40	995 LA	PAGE 66	
099 TG	PAGE 76	324 LTX/SH5	PAGE 86	516 SA/C4	PAGE 21	519 ACT13	PAGE 7	687 1/2" C16	PAGE 96	997 A	PAGE 71	
100			324 SH5	PAGE 36	516 SA/CA1	PAGE 20	519 ACT14	PAGE 7	688 3/4" MD6	PAGE 96	997 B	PAGE 71
115 CL/SE2	PAGE 86	324 SH8	PAGE 36	516 SA/CA2	PAGE 20	519 ACT15	PAGE 9	692 J32	PAGE 40	1000		
127 C/SE4	PAGE 45	324 SH12	PAGE 37	516 SA/CA3	PAGE 21	519 M 091A	PAGE 29	692 J49	PAGE 40	1612 BA12	PAGE 79	
127 C/SE4S	PAGE 45	324 STX/S7	PAGE 37	516 SA/CA4	PAGE 21	519 M 127N	PAGE 29	692 J100	PAGE 41	1612 BA24	PAGE 79	
127 N/SE4	PAGE 45	324 XP/B16	PAGE 5	516 SP6EX	PAGE 19	519 M 150AX	PAGE 29	700			1613 AGM12-24	PAGE 78
127 N/SE4S	PAGE 45	333 K/SB10	PAGE 38	516 SP6NEX	PAGE 19	519 M 276	PAGE 29	751	PAGE 64	1613 OBD	PAGE 79	
146 B	PAGE 64	333 K/SC23	PAGE 38	516 SPC1	PAGE 22	519 M 280HG	PAGE 29	753 KA	PAGE 64	1613 RA12	PAGE 78	
150 AX/SE3	PAGE 44	333 K/SH8	PAGE 38	516 SPC2	PAGE 22	519 M 280HGTS	PAGE 29	767	PAGE 64	1651	PAGE 79	
155 AX	PAGE 44	341 SH33	PAGE 64	516 SPCN1	PAGE 22	519 M 280N1	PAGE 29	800			1785 B	PAGE 89
163	PAGE 64	367 SE6	PAGE 69	516 SPCN2	PAGE 22	519 M 280TK	PAGE 29	810 N	PAGE 61	1881 S22	PAGE 79	
174 CX	PAGE 46	376	PAGE 69	516 ST5HYA-S	PAGE 77	519 M 285A1	PAGE 29	810 SA	PAGE 60	1950 C	PAGE 82	
200			382	PAGE 69	516 ST5V	PAGE 14	519 M 285A2	PAGE 29	811 NE	PAGE 61	2000	
200 S	PAGE 71	391	PAGE 86	516 ST6MA	PAGE 17	519 M 285KA	PAGE 29	811 SE	PAGE 60	2000 A	PAGE 89	
207 D	PAGE 63	400			516 ST6MM	PAGE 17	519 M 322H	PAGE 29	812 N	PAGE 61	2550 A	PAGE 82
207 E	PAGE 63	400 P	PAGE 88	516 ST6NMA	PAGE 17	519 M 322STX	PAGE 29	814 A	PAGE 62	2550 B	PAGE 82	
233 1/2" MNTX/C6	PAGE 96	426 B/S5	PAGE 88	516 ST6NMM	PAGE 17	519 M 324H	PAGE 29	824 A	PAGE 61	2847/3	PAGE 81	
235 1/2" MB/C10	PAGE 98	426 C/S4	PAGE 88	516 ST6NPA	PAGE 16	519 M 324STX	PAGE 29	828 X4	PAGE 62	2847 N4	PAGE 81	
235 1/2" M/C16	PAGE 97	426 D/S4	PAGE 88	516 ST6NPM	PAGE 16	519 M 382F	PAGE 29	831 A	PAGE 62	3000		
235 3/4" M/C8	PAGE 97	426 SAB	PAGE 88	516 ST6NV	PAGE 14	519 M 613AEA	PAGE 29	870 C	PAGE 87	3781 A	PAGE 89	
235 3/4" MLS	PAGE 83	443 N	PAGE 84	516 ST6PA	PAGE 16	519 M 613BEA	PAGE 29	871 C	PAGE 87	3781 C	PAGE 89	
236 K	PAGE 99	443 NC	PAGE 84	516 ST6PM	PAGE 16	519 M 613CEA	PAGE 29	871 D	PAGE 87	3781 D	PAGE 89	
236 KE	PAGE 99	446 DA/SE6	PAGE 84	516 ST6V	PAGE 14	519 M 990A5MD	PAGE 29	884 C/S6	PAGE 87	3781 E	PAGE 89	
236 KE/C22	PAGE 99	446 DT/S2	PAGE 85	516 ST7NV	PAGE 14	519 R8/3M-S	PAGE 11	885 F	PAGE 87	5000		
237 1/2" AK	PAGE 55	446 E/SE2	PAGE 84	516 ST7V	PAGE 14	519 RBO7/3V	PAGE 9	889 LTE	PAGE 75	5003/1	PAGE 33	
237 1/4" AK	PAGE 55	446 S28	PAGE 85	516 STC4V	PAGE 15	519 RBU6/3V	PAGE 9	889 RD	PAGE 74	5006 EF2	PAGE 25	
237 D	PAGE 53	447 T	PAGE 80	516 STS6NV	PAGE 14	519 RS6/3MA	PAGE 10	889 RP	PAGE 75	5006 EF4	PAGE 25	
252 N/SR8	PAGE 51	449 TA	PAGE 83	516 STXL6MM	PAGE 18	519 RS6/3MM	PAGE 10	889 RT	PAGE 75			
263/S16	PAGE 85	449 TB	PAGE 83	516 STXL6NMM	PAGE 18	519 RS6/3NMA	PAGE 10	889 SA	PAGE 74			
270 BM	PAGE 81	449 TC	PAGE 83	516 STXL6NV	PAGE 14	519 RS6/3NMM	PAGE 10	889 TR	PAGE 74			
270 C/C3	PAGE 81	451 N/S4	PAGE 59	516 STXL6V	PAGE 14	519 RS6/3NV	PAGE 8	890 K	PAGE 79			
272 DS	PAGE 80	454	PAGE 59	516 SU2V	PAGE 15	519 RS6/3V	PAGE 8	900				
276 CE/SE8	PAGE 51	458 E/B9	PAGE 58	516 SUXLV	PAGE 15	519 RS6/4MM	PAGE 11	910 E1 1"	PAGE 93			
280 HAP/SE6	PAGE 43	458 S6	PAGE 59	519/127N	PAGE 28	519 RS6/4NMM	PAGE 11	913 PB2 3/8"	PAGE 92			
280 HATX/SE6	PAGE 43	458 S20	PAGE 58	519/150AX	PAGE 28	519 RS6/4NV	PAGE 8	913 PC2 1/2"	PAGE 92			
280 HG/SE6	PAGE 43	460 A	PAGE 59	519/276	PAGE 28	519 RS6/4V	PAGE 8	920 AN1	PAGE 94			
280 HGTS/SE6	PAGE 43	468 M	PAGE 87	519/280HG	PAGE 28	519 RS7/3V	PAGE 8	921 A4	PAGE 94			
280 LTS/S9	PAGE 41	493 A	PAGE 73	519/280HGTS	PAGE 28	519 RS7/5V	PAGE 8	921 B1	PAGE 94			

DISCOVER THE NEWS 2022

NEW



Electrical screwdriver
Page 4

NEW



Roller cabinets
Page 6

NEW



Plier wrench
Page 46

NEW



Controlled tightening
Page 60



Workshop furniture
Page 20



Workbenches
Page 22



Van fitting storage
Page 24

NEW

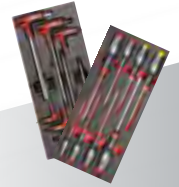

Assortments
Page 26



Maintenance suitcases
Page 30



Portable storage
Page 32

NEW



Screwdrivers
Page 36



Hexagon keys and bits
Page 40



Pliers
Page 44



Wrenches
Page 47

NEW



Ratchets and sockets
Page 52

NEW



Pullers
Page 58



Electrician scissors
Page 63



Electrotechnics
Page 64

NEW



Rivet pliers
Page 66



Plumbing
Page 68



Maintenance
Page 69

NEW



Lighting
Page 74

NEW



Automotive
Page 76

NEW



Air tools and accessories
Page 90



LOOK FOR THE ICONIC PRODUCTS:
the tools that make the difference!



POWER ASSIST SCREWDRIVER 324 XP

SPEED OF THE BATTERY, ACCURACY OF YOUR HAND



MAGNETIC BIT HOLDER
with quick release chuck.



HANDLE
ergonomic in oil and chemicals resistant rubber.

IEC 60529



LIGHT
with 5 frontal LED with automatic switch-off at 10 seconds.



AUTOMATIC LOCKING SYSTEM
of the chuck to apply the torque by hand

CE
EN 60529

TECHNICAL CHARACTERISTICS	
Vibrations (mm/s ²)	1,4
Sound power dB(A)	54
Dimensions (mm)	170x39
Weight (gr)	245



LITHIUM
3.6V - 2.0 Ah
lithium battery.

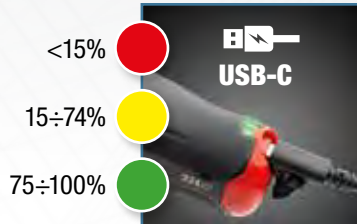

RECHARGEABLE
LED indicator of the battery charge status. Complete recharge in 70 minutes. (IN: 5V = 3A).

POWER ASSIST SCREWDRIVER

300 rpm



ITS SPEED
Works with 300 rpm speed coming from the electric engine.

YOUR ACCURACY
Close the tightening with the accuracy of a standard screwdriver.



0,9 Nm

10 Nm

Electrical screwdriver

16
PIECES



324 XP/B16
Code U03240801



High resistance nylon

Bag with power assist screwdriver and bits

- Set with long bits, power assist screwdriver and nylon bag
- Internal electric engine to give speed
- Compact dimensions to allow use by hand
- 3.6V Lithium battery with 2.0 Ah capacity
- Magnetic 1/4" bits holder with quick release ring
- 5 front side LED with 10 seconds automatic switch-off
- Automatic locking system of the chuck to apply the torque by hand
- Ergonomic rubber handle resistant to oils and chemicals
- IP54 protection
- Rechargeable with USB-C cable (included)
- LED charge status
- High resistance nylon bag with belt hook
- Bits holder elastics and USB-C cable pocket



Bits holding elastics



Internal pocket for the USB-C cable



Belt hook

DESCRIPTION	ITEM/SIZE	PCS.
Power assist screwdriver	324 XP	1
Long bits - slot-head (50 mm)	664/0,6x4-0,8x5,5	2
Long bits - hexagonal (50 mm)	664 E 3-4-5-6	4
Long bits - PHILLIPS® (75 mm)	664 PH 1-2	2
Long bits - POZIDRIV® (75 mm)	664 PZ 1-2	2
Long bits - TORX® (70 mm)	664 TX T10-T15-T20-T25-T30	5

QUICK TIGHTENING OF DELICATE PARTS



APPLICATIONS IN NARROW SPACES





519 RACING ROLLER CABINET YOUR PREMIUM AND PROFESSIONAL WORKSHOP.

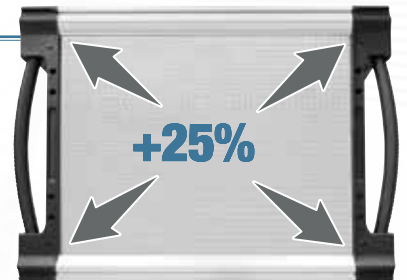

**A NEW WIDER WORKTOP
WITH DOUBLE HANDLE**

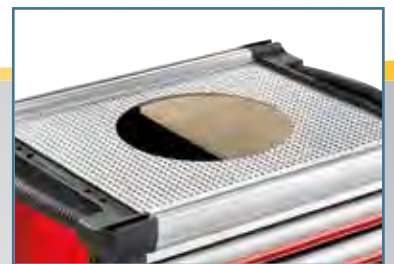

DOUBLE LAYER

Above: 2 mm aluminium plate.
Below: 15 mm wooden piece.



**TWO WHEELS
WITH BRAKE**



**RUBBER BUMPERS
ON STRUCTURE AND
DRAWERS**



**NEW ALUMINIUM ERGONOMIC
HANDLES WITH SELECTIVE
OPENING**



**SLIDES WITH SOFT CLOSE
SYSTEM**

Roller cabinets

NEW



519 ACT1

Code U05190301

Laptop holder

NEW



519 ACT2

Code U05190302

Bottle and paper roll holder



YouTube

NEW



519 ACT3

Code U05190303

Drawers locking bar

NEW

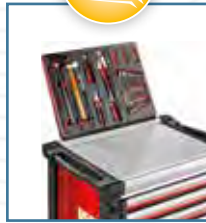

519 ACT4

Code U05190304

Panel for documents and foam modules

NEW



519 ACT5

Code U05190305

Document holder

NEW



519 ACT6

Code U05190306

Wooden top M3 (775 mm)

NEW



519 ACT7

Code U05190307

Wooden top M4 (965 mm)

NEW



519 ACT8

Code U05190308

Wooden top M5 (1155 mm)

NEW



519 ACT9

Code U05190309

Wooden top for vice

NEW



519 ACT10

Code U05190310

Back hooks

NEW



519 ACT11

Code U05190311

Perforated panel with shelf

NEW



519 ACT12

Code U05190312

Double perforated panel

NEW



519 ACT13

Code U05190313

Perforated/flat panel with shelf

NEW

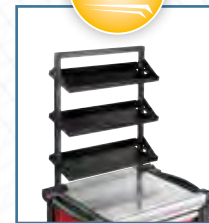

519 ACT14

Code U05190314

Triple shelf



CREATE THE IDEAL ROLLER CABINET FOR YOUR JOB.

The new worktop has an integrated system that allows to fix a new range of specific accessories. Together with the use of standard side accessories (page 13) you can turn your RACING into a real professional workstation.

Roller cabinets



900 kg

NEW

8
DRAWERS

3
MODULES

79 kg | mm | → 814
↓ 1005
↙ 575

519 RS8/3V

Code U05190508

RAL 3020

RACING roller cabinet (empty)

- Inside dimensions:
6 drawers 570x420x60 mm
2 drawers 570x420x130 mm



900 kg

NEW

7
DRAWERS

3
MODULES

77 kg | mm | → 814
↓ 1005
↙ 575

519 RS7/3V

Code U05190507

RAL 3020

RACING roller cabinet (empty)

- Inside dimensions:
5 drawers 570x420x60 mm
1 drawer 570x420x130 mm
1 drawer 570x420x270 mm



900 kg

NEW

6
DRAWERS

3
MODULES

75 kg | mm | → 814
↓ 1005
↙ 575

519 RS6/3V

Code U05190506

RAL 3020

RACING roller cabinet (empty)

519 RS6/3NV

Code U05190516

RAL 9005

RACING roller cabinet (empty)

- Inside dimensions:
4 drawers 570x420x60 mm
1 drawer 570x420x130 mm
1 drawer 570x420x270 mm



1000 kg

NEW

6
DRAWERS

4
MODULES

89 kg | mm | → 1004
↓ 1005
↙ 575

519 RS6/4V

Code U05190546

RAL 3020

RACING roller cabinet (empty)

519 RS6/4NV

Code U05190566

RAL 9005

RACING roller cabinet (empty)

- Inside dimensions:
4 drawers 760x420x60 mm
1 drawer 760x420x130 mm
1 drawer 760x420x270 mm



1100 kg

NEW

7
DRAWERS

5
MODULES

106 kg | mm | → 1194
↓ 1035
↙ 575

519 RS7/5V

Code U05190556

RAL 3020

RACING roller cabinet (empty)

- Inside dimensions:
5 drawers 950x420x60 mm
1 drawer 950x420x130 mm
1 drawer 950x420x270 mm



SAVE YOUR TIME

All USAG roller cabinets are immediately ready for use, because they are supplied with the wheels already mounted on the structure





7 DRAWERS
3 MODULES

106 kg | 1194 mm | 1035 mm | 575 mm

519 RB07/3V

Code U05190097

RAL 3020

RACING roller cabinet with side door (empty)

- Inside dimensions:
5 drawers 570x420x60 mm
1 drawer 570x420x130 mm
1 drawer 570x420x200 mm
- Side cabinet: 380x400x720 mm



6 DRAWERS
3 MODULES

128 kg | 1.212 mm | 1000 mm | 670 mm

519 RBU6/3V

Code U05190098

RAL 3020

RACING mobile workbench (empty)

- Inside dimensions of the drawers:
3 drawers 570 x420x60 mm
2 drawers 570 x420x130 mm
1 drawer 570 x420x200 mm
- Side compartment: 380x704x524 mm



519 ACT15

Code U05190315

Transportation kit for RACING chest

- Accessory dedicated only for the drawer chest RACING RSC4
- Includes:
Metal handle
Wheels (Ø 125 mm): two fixed and two swivelling, one of which has a brake



4 DRAWERS
3 MODULES

45 kg | 814 mm | 500 mm | 575 mm

519 RSC4/3V

Code U05190534

RAL 3020

RACING drawer chest (empty)

- Inside dimensions:
3 drawers 570x420x60 mm
1 drawer 570x420x130 mm



4 DRAWERS
4 MODULES

51 kg | 1004 mm | 500 mm | 575 mm

519 RSC4/4V

Code U05190544

RAL 3020

RACING drawer chest (empty)

- Inside dimensions:
3 drawers 760x420x60 mm
1 drawer 760x420x130 mm



4 DRAWERS
5 MODULES

60 kg | 1194 mm | 500 mm | 575 mm

519 RSC4/5V

Code U05190554

RAL 3020

RACING drawer chest (empty)

- Inside dimensions:
3 drawers 950x420x60 mm
1 drawer 950x420x130 mm

Roller cabinets

CAN'T FIND
Go now to



6
DRAWERS

3
MODULES



6
DRAWERS

3
MODULES



519 RS6/3MM
Code U05190628

RAL 3020



519 RS6/3MA
Code U05190627

RAL 3020

156
PIECES

519 RS6/3NMM
Code U05191628

RAL 9005

155
PIECES

519 RS6/3NMA
Code U05191627

RAL 9005

RACING roller cabinet with assortment for MAINTENANCE 495 MB - 4 drawers

RACING roller cabinet with AUTOMOTIVE assortment 495 MAA - 3 drawers



MAINTENANCE ASSORTMENT



519 M 613AEA 519 M 613CEA 519 M 285A1



519 M 127C 519 M 150AX 519 MSK6

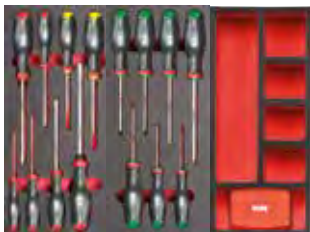

519 M 324H 519 M 324STX 519 MSK6+ 692 J32



519 M 990A5MD 519 M 382 519 MSK6

AUTOMOTIVE ASSORTMENT



519 M 285A1 519 M 324H 519 M 324STX



519 M 613AEA 519 M 612CLA

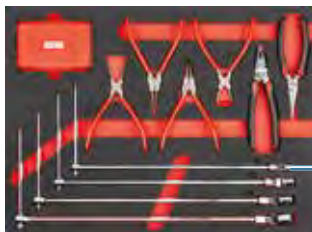

519 M 276C



T-WRENCHES WITH JOINT
8-10-13-17 mm

DESCRIPTION	ITEM	PCS.
Hexagonal sockets, ratchet (237 A 1/4"), accessories 1/4" and bits	519 M 613AEA	46
Hexagonal sockets, ratchet (237 A 1/2") and accessories 1/2"	519 M 613CEA	23
Combination wrenches (6-7-8-9-10-11-12-13-14-15-16-17-18-19-21-22-24 mm)	519 M 285A1	17
Pliers for circlips internal and external 15÷25 and 19÷60	519 M 127C	6
Universal pliers, adjustable pliers, cutting nippers, extra-long nose pliers, lock-grip pliers	519 M 150AX	5
Screwdrivers for slot-head and PHILLIPS® screws	519 M 324H	8
Screwdrivers for TORX® Tamper Resistant screws (T10-T15-T20-T25-T30-T40)	519 M 324STX	7
Flat square file, half-round file, round file, square file, triangular file (second cut)	519 M 990A5MD	5
Hammer for mechanics with graphite handle, mallet, pin punches, chisel and centre punch	519 M 382F	7
Assortment with bits and reversible ratchet	692 J32	32

DESCRIPTION	ITEM	PCS.
Hexagonal sockets, ratchet (237 A 1/4"), accessories 1/4" and bits	519 M 613AEA	46
Bihexagonal sockets, ratchet (237 A 1/2") and accessories 1/2"	519 M 612CLA	35
Combination wrenches (6-7-8-9-10-11-12-13-14-15-16-17-18-19-21-22-24 mm)	519 M 285A1	17
Screwdrivers for slot-head and PHILLIPS® screws	519 M 324H	8
Screwdrivers for TORX® Tamper Resistant screws	519 M 324STX	7
Pliers for circlips, combination pliers, long nose pliers, T-handle wrenches with hex sockets (8-10-13-17 mm), bits set with ratchet	519 M 276C	42

YOUR IDEAL ASSORTMENT? Kitplanner-gb.usag.it and create it!



6
DRAWERS

4
MODULES

NEW

519 RS6/4MM
Code U05190632

RAL 3020

301
PIECES

519 RS6/4NMM
Code U05191632

RAL 9005

RACING roller cabinet with assortment for MAINTENANCE 495 MC - 4 drawers



8
DRAWERS

3
MODULES

318
PIECES

519 R8/3M-S
Code U05198024

RAL 3020

RACING roller cabinet with assortment for MAINTENANCE - 4 drawers



MAINTENANCE ASSORTMENT



519 M 612CLA 519 M 613BEA 519 M 613AEA 519 M 285KA 519 M 285A1 519 M 285A2 519 M 294B



519 M 324H 519 M 324STX 519 M 280HG 519 M 280N1 519 M 127C 519 M 150AX 519 M 382F 519 M 990A5MD

DESCRIPTION	ITEM	PCS.
Hexagonal sockets, ratchet (237 A 1/4"), accessories 1/4" and bits	519 M 613AEA	46
Hexagonal sockets, ratchet (237 A 3/8") and accessories 3/8"	519 M 613BEA	20
Bihexagonal sockets, ratchet (237 A 1/2") and accessories 1/2"	519 M 612CLA	35
Reversible ratchet combination wrenches 8-9-10-11-12-13-14-15-16-17-18-19 mm	519 M 285 KA	12
Combination wrenches (6-7-8-9-10-11-12-13-14-15-16-17-18-19-21-22-24 mm)	519 M 285A1	17
Combination wrenches 27-29-30-32-34 mm	519 M 285A2	5
Adjustable wrenches, lock-grip pliers and scissor	519 M 294B	4
Screwdrivers for slot-head and PHILLIPS® screws	519 M 324H	8
Screwdrivers for TORX® Tamper Resistant screws (T10-T15-T20-T25-T30-T40)	519 M 324STX	7
Hexagon keys with handgrip (3-4-5-6-7-8-10 mm)	519 M 280HG	7
Set of keys for TORX® screws and assortment of bits with special shapes	519 M 280N1	117
Pliers for circlips internal and external 15÷25 and 19÷60	519 M 127C	6
Universal pliers, adjustable pliers, cutting nippers, extra-long nose pliers, lock-grip pliers	519 M 150AX	5
Flat square file, half-round file, round file, square file, triangular file (second cut)	519 M 990A5MD	5
Hammer for mechanics with graphite handle, mallet, pin punches, chisel and centre punch	519 M 382F	7

MAINTENANCE ASSORTMENT



519 M 612CLA 519 M 613BEA 519 M 613AEA 519 M 285KA 519 M 285A1 519 M 285A2 519 M 233C24

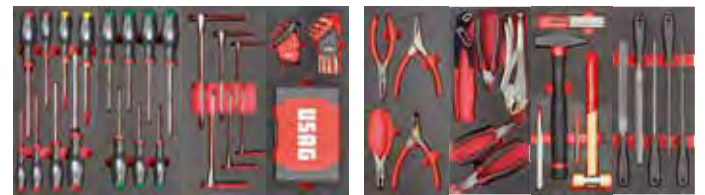

519 M 324H 519 M 324STX 519 M 280TK 519 M 280N1 519 M 127N 519 M 150AX 519 M 382F 519 M 990A5MD

DESCRIPTION	ITEM	PCS.
Hexagonal sockets, ratchet (237 A 1/4"), accessories 1/4" and bits	519 M 613AEA	46
Hexagonal sockets, ratchet (237 A 3/8") and accessories 3/8"	519 M 613BEA	20
Bihexagonal sockets, ratchet (237 A 1/2") and accessories 1/2"	519 M 612CLA	35
Reversible ratchet combination wrenches 8-9-10-11-12-13-14-15-16-17-18-19 mm	519 M 285 KA	12
Combination wrenches (6-7-8-9-10-11-12-13-14-15-16-17-18-19-21-22-24 mm)	519 M 285A1	17
Combination wrenches 27-29-30-32-34 mm	519 M 285A2	5
Socket bits for TORX® screws and bits TORX®, XZN, Hexagonal, Ribe	519 M 233 C24	24
Screwdrivers for slot-head and PHILLIPS® screws	519 M 324H	8
Screwdrivers for TORX® Tamper Resistant screws (T10-T15-T20-T25-T30-T40)	519 M 324STX	7
T-handle hexagonal keys with sliding bar 2,5-3-4-5-6-8 mm	519 M 280TK	6
Set of keys for TORX® screws and assortment of bits with special shapes	519 M 280N1	117
Pliers for circlips 19÷60 mm	519 M 127N	4
Universal pliers, adjustable pliers, cutting nippers, extra-long nose pliers, lock-grip pliers	519 M 150AX	5
Flat square file, half-round file, round file, square file, triangular file (second cut)	519 M 990A5MD	5
Hammer for mechanics with graphite handle, mallet, pin punches, chisel and centre punch	519 M 382F	7

Do you want only the assortment? Go to page 26



516 START ROLLER CABINET MORE RESISTANT AND RELIABLE.

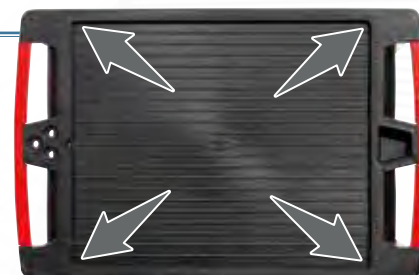

**NEW WORKTOP 460 X 560 mm
WITH 15 mm SIDES**



**STABLE AND CAPACIOUS:
515 mm TOTAL DEPTH**



**HIGH RESISTANCE 35 mm
SLIDES WITH A LOAD CAPACITY
UP TO 40 kg**



**NEW DRAWER HANDLES IN HIGH
RESISTANT ABS WITH SELECTIVE
OPENING**

ACCESSORIES RANGE FOR 516 START ROLLER CABINETS



516 AC1
Code U05160301
Paper roll holder



516 AC2
Code U05160302
Bottle holder



516 AC3
Code U05160303
Document holder



516 AC4
Code U05160304
Waste holder



516 AC5
Code U05160305
Side cabinet with lock



516 AC6
Code U05160306
Foldable shelf



516 AC7
Code U05160307
Power tools holder



516 AC8
Code U05160308
Side power connection
• Cable length: 1.8 m



516 AC9
Code U05160309
Wooden top
• 15 mm thickness

COMPLETE YOUR ROLLER CABINET AND MAKE IT PERFECT

All the roller cabinets of the 516 START range could be completed with the new range of lateral accessories.

They are easy to be fixed, adding new features for different destinations of use. The new 516 START accessories range is compatible also with all the 519 RACING models and with the 516 START workshop furniture line.



Roller cabinets



800 kg

NEW

5
DRAWERS

3
MODULES



516 ST5V
Code U05160105

RAL 3020

START roller cabinet (empty)

- Inside dimensions:
2 drawers 570x420x60 mm
2 drawers 570x420x130 mm
1 drawer 570x420x270 mm



800 kg

NEW

6
DRAWERS

3
MODULES



516 ST6V
Code U05160106

RAL 3020

START roller cabinet (empty)

516 ST6NV
Code U05160116

RAL 9005

START roller cabinet (empty)

- Inside dimensions:
3 drawers 570x420x60 mm
2 drawers 570x420x130 mm
1 drawer 570x420x200 mm



800 kg

NEW

7
DRAWERS

3
MODULES



516 ST7V
Code U05160107

RAL 3020

START roller cabinet (empty)

516 ST7NV
Code U05160117

RAL 9005

START roller cabinet (empty)

- Inside dimensions:
5 drawers 570x420x60 mm
1 drawers 570x420x130 mm
1 drawer 570x420x200 mm



800 kg

NEW

6
DRAWERS

4
MODULES



516 STXL6V
Code U05160146

RAL 3020

START XL roller cabinet (empty)

516 STXL6NV
Code U05160156

RAL 9005

START XL roller cabinet (empty)

- Inside dimensions:
3 drawers 760x420x60 mm
2 drawers 760x420x130 mm
1 drawer 760x420x200 mm

Safety Lock System



800 kg



NEW

6
DRAWERS

3
MODULES



516 STS6NV
Code U05160136

RAL 9005

START roller cabinet with Safety Lock System - 6 drawers (empty)

- Inside dimensions:
3 drawers 570x420x60 mm
2 drawers 570x420x130 mm
1 drawer 570x420x200 mm



SAVE YOUR TIME

All USAG roller cabinets are immediately ready for use, because they are supplied with the wheels already mounted on the structure



Double drawer



**COMPATIBLE
WITH 516 START
ACCESSORIES**

516 SU2V
Code U05160002

RAL
3020



START utility chart (empty)

- Work top in high resistant ABS with built-in 15 mm edges to prevent objects from falling during transport
- Shelves with edges to prevent objects from falling during transport and plastic cover
- Delivered disassembled
- Inside dimensions: 2 drawers 570x420x60 mm

Extra-large model



**COMPATIBLE
WITH 516 START
ACCESSORIES**

516 SUXLV
Code U05160003

RAL
3020



START XL utility chart

- Work top in high resistant ABS with built-in 15 mm edges to prevent objects from falling during transport
- Shelves with edges to prevent objects from falling during transport and plastic cover
- Delivered disassembled

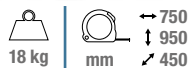

504 S
Code U05040003

RAL
3020

Multi-purpose roller cabinet with 3 shelves

- Shelves with edges to prevent objects from falling during transport
- Steel handle for optimal manoeuvrability
- Oil-proof rubber wheels (Ø 100 mm): two fixed and two swivelling, one of which has a brake
- Spare kit with 4 wheels: code 1004735-79
- Supplied disassembled

516 STC4V
Code U05160104

RAL
3020

START drawer chest - 4 drawers (empty)

- Inside dimensions:
3 drawers 570x420x60 mm
1 drawers 570x420x130 mm



516 AC10
Code U05160310

Transportation kit for START chest

- Accessory dedicated only for the drawer chest START 516 SPC
- Includes:
Metal handle
Wheels (Ø 125 mm): two fixed and two swivelling, one of which has a brake

Roller cabinets



CAN'T FIND
Go now to

6
DRAWERS

3
MODULES



6
DRAWERS

3
MODULES



516 ST6PM
Code U05160630

RAL 3020



516 ST6PA
Code U05160629

RAL 3020

157
PIECES

516 ST6NPM
Code U05161630

RAL 9005

START roller cabinet with MAINTENANCE assortment 495 PM - 4 drawers



142
PIECES

516 ST6NPA
Code U05161629

RAL 9005

START roller cabinet with AUTOMOTIVE assortment 495 PA - 2 drawers



MAINTENANCE ASSORTMENT



519/613AEA 519/613CEA 519 SK692V



519/285A1 519/150AX 519 SK692V

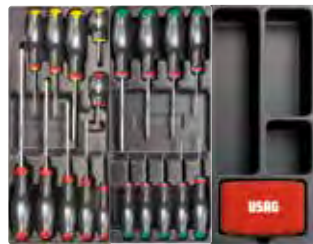

519/324H 519/324TX 519 SK692V + 692 J32



519 SK692V 519/990A1 519/382F

AUTOMOTIVE ASSORTMENT



519/613AEA 519/613CEA 519 SK692V + 692 J32



519/324H 519/285A1 519/150AX

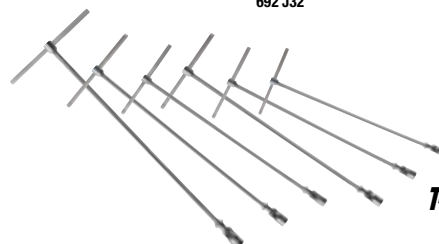

T-WRENCHES WITH JOINT
7-8-10-12-13-17 mm

DESCRIPTION	ITEM	PCS.
Hexagonal sockets, ratchet (237 A 1/4"), accessories 1/4" and bits	519/613AEA	42
Hexagonal sockets, ratchet (237 A 1/2") and accessories 1/2"	519/613CEA	22
Combination wrenches (6-7-8-9-10-11-12-13-14-15-16-17-18-19-22-24 mm) and angled keys (1,5-2-2,5-3-4-5-6-8-10 mm)	519/285A1	25
Universal pliers, adjustable pliers, cutting nippers, extra-long nose pliers, lock-grip pliers	519/150AX	5
Screwdrivers for slot-head and PHILLIPS® screws	519/324H	10
Screwdrivers for TORX® screws	519/324TX	9
Flat square file, half-round file, round file, triangular file (second cut)	519/990A1	4
Hammers, chisels and pin punches	519/382F	8
Assortment with bits and reversible ratchet	692 J32	32

DESCRIPTION	ITEM	PCS.
Hexagonal sockets, ratchet (237 A 1/4"), accessories 1/4" and bits	519/613AEA	42
Hexagonal sockets, ratchet (237 A 1/2") and accessories 1/2"	519/613CEA	22
Screwdrivers for slot-head and PHILLIPS® screws	519/324H	10
Combination wrenches (6-7-8-9-10-11-12-13-14-15-16-17-18-19-22-24 mm) and angled keys (1,5-2-2,5-3-4-5-6-8-10 mm)	519/285A1	25
Universal pliers, adjustable pliers, cutting nippers, extra-long nose pliers, lock-grip pliers	519/150AX	5
T-handle wrenches with jointed hexagonal socket (7-8-10-12-13-17 mm)	276 CE	6
Assortment with bits and reversible ratchet	692 J32	32

YOUR IDEAL ASSORTMENT? Kitplanner-gb.usag.it and create it!



6
DRAWERS

3
MODULES



6
DRAWERS

3
MODULES



516 ST6MM
Code U05160628

RAL
3020

156
PIECES

516 ST6NMM
Code U05161628

RAL
9005

**START XL roller cabinet with assortment
for MAINTENANCE 495 MB - 4 drawers**



516 ST6MA
Code U05160627

RAL
3020

155
PIECES

516 ST6NMA
Code U05161627

RAL
9005

**START roller cabinet with AUTOMOTIVE
assortment 495 MAA - 3 drawers**



MAINTENANCE ASSORTMENT



519 M 613AEA 519 M 613CEA 519 M 285A1



519 M 127C 519 M 150AX 519 MSK6

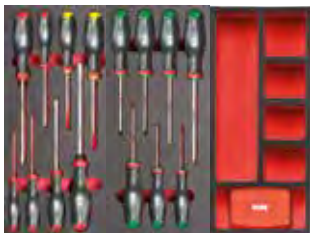

519 M 324H 519 M 324STX 519 MSK6+
692 J32



519 M 990A5MD 519 M 382 519 MSK6

AUTOMOTIVE ASSORTMENT



519 M 285A1 519 M 324H 519 M 324STX



519 M 613AEA 519 M 612CLA

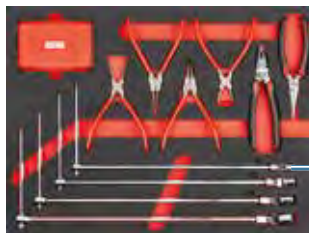

519 M 276C



T-WRENCHES WITH JOINT
8-10-13-17 mm

DESCRIPTION	ITEM	PCS.
Hexagonal sockets, ratchet (237 A 1/4"), accessories 1/4" and bits	519 M 613AEA	46
Hexagonal sockets, ratchet (237 A 1/2") and accessories 1/2"	519 M 613CEA	23
Combination wrenches (6-7-8-9-10-11-12-13-14-15-16-17-18-19-21-22-24 mm)	519 M 285A1	17
Pliers for circlips internal and external 15÷25 and 19÷60	519 M 127C	6
Universal pliers, adjustable pliers, cutting nippers, extra-long nose pliers, lock-grip pliers	519 M 150AX	5
Screwdrivers for slot-head and PHILLIPS® screws	519 M 324H	8
Screwdrivers for TORX® Tamper Resistant screws	519 M 324STX	7
Flat square file, half-round file, round file, square file, triangular file (second cut)	519 M 990A5MD	5
Hammer for mechanics with graphite handle, mallet, pin punches, chisel and centre punch	519 M 382F	7
Assortment with bits and reversible ratchet	692 J32	32

DESCRIPTION	ITEM	PCS.
Hexagonal sockets, ratchet (237 A 1/4"), accessories 1/4" and bits	519 M 613AEA	46
Bihexagonal sockets, ratchet (237 A 1/2") and accessories 1/2"	519 M 612CLA	35
Combination wrenches (6-7-8-9-10-11-12-13-14-15-16-17-18-19-21-22-24 mm)	519 M 285A1	17
Screwdrivers for slot-head and PHILLIPS® screws	519 M 324H	8
Screwdrivers for TORX® Tamper Resistant screws	519 M 324STX	7
Pliers for circlips, combination pliers, long nose pliers, T-handle wrenches with hex sockets (8-10-13-17 mm), bits set with ratchet	519 M 276C	42

Do you want only the assortment? Go to page 26

Roller cabinets

CAN'T FIND
Go now to



6
DRAWERS

4
MODULES

NEW

301
PIECES

516 STXL6MM
Code U05160632

RAL
3020

START XL roller cabinet with assortment for MAINTENANCE 495 MC - 4 drawers



6
DRAWERS

4
MODULES

NEW

301
PIECES

516 STXL6NMM
Code U05161632

RAL
9005

START XL roller cabinet with assortment for MAINTENANCE 495 MC - 4 drawers



MAINTENANCE ASSORTMENT



519 M 612CLA

519 M 613BEA

519 M 613AEA

519 M 285KA

519 M 285A1

519 M 285A2

519 M 294B

519 M 324H

519 M 324STX

519 M 280HG

519 M 280N1

519 M 127C

519 M 150AX

519 M 382F

519 M 990A5MD

DESCRIPTION	ITEM	PCS.	DESCRIPTION	ITEM	PCS.
Hexagonal sockets, ratchet (237 A 1/4"), accessories 1/4" and bits	519 M 613AEA	46	Screwdrivers for TORX® Tamper Resistant screws	519 M 324STX	7
Hexagonal sockets, ratchet (237 A 3/8") and accessories 3/8"	519 M 613BEA	20	Hexagon keys with handgrip (3-4-5-6-7-8-10 mm)	519 M 280HG	7
Bihexagonal sockets, ratchet (237 A 1/2") and accessories 1/2"	519 M 612CLA	35	Set of keys for TORX® screws and assortment of bits with special shapes	519 M 280N1	117
Reversible ratchet combination wrenches 8-9-10-11-12-13-14-15-16-17-18-19 mm	519 M 285 KA	12	Pliers for circlips internal and external 15÷25 and 19÷60	519 M 127C	6
Combination wrenches (6-7-8-9-10-11-12-13-14-15-16-17-18-19-21-22-24 mm)	519 M 285A1	17	Universal pliers, adjustable pliers, cutting nippers, extra-long nose pliers, lock-grip pliers	519 M 150AX	5
Combination wrenches 27-29-30-32-34 mm	519 M 285A2	5	Flat square file, half-round file, round file, square file, triangular file (second cut)	519 M 990A5MD	5
Adjustable wrenches, lock-grip pliers and scissor	519 M 294B	4	Hammer for mechanics with graphite handle, mallet, pin punches, chisel and centre punch	519 M 382F	7
Screwdrivers for slot-head and PHILLIPS® screws	519 M 324H	8			

YOUR IDEAL ASSORTMENT? Kitplanner-gb.usag.it and create it!



6
DRAWERS

3
MODULES



6
DRAWERS

3
MODULES

263
PIECES

516 SP6EX
Code U05168205E

RAL
3020

START roller cabinet with assortment for maintenance



263
PIECES

516 SP6NEX
Code U05168206E

RAL
9005

START roller cabinet with assortment for maintenance



MAINTENANCE ASSORTMENT



519 M 382F

519 M 127N

519 M 280N1



519 M 322H

519 M 322STX

519 M 150AX

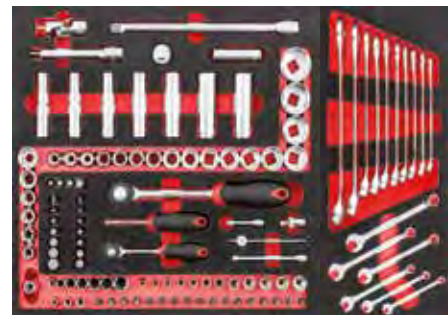

601 1/4-1/2 J100

285 J/B16

DESCRIPTION	ITEM	PCS.
Hexagonal sockets, ratchet, bits and accessories 1/4"-1/2"	601 1/4-1/2 J100	100
Combination wrenches (6÷24)	285 J/B16	16
Universal pliers, adjustable pliers, cutting nippes, extra-long nose pliers and lock-grip pliers	519 M 150AX	5

DESCRIPTION	ITEM	PCS.
Hammer, chisels and pin punches	519 M 382F	7
Pliers for circlips (19÷60)	519 M 127N	4
Screwdrivers for slot-head and PHILLIPS® screws	519 M 322H	8
Screwdrivers for TORX® and Tamper Resistant screws	519 M 322STX	6
Set of angled hexagon keys, set of keys for TORX® screws and assortment of bits with special shapes	519 M 280N1	117



YouTube



CHOOSE YOUR

Try it now: go to

STEEL

516 SA/CA1

Code U05160235

135 kg | 1.450 mm | 2.000 mm | 650

Steel top
1.450 mm
516 AC/1

Workshop furniture - steel top

- Supplied with 30 hooks (kit 516 SA/K1)

WOOD

516 SA/C1

Code U05160231

127 kg | 1.450 mm | 2.000 mm | 650

Wooden top
1.450 mm
516 SAL/1

Workshop furniture - wooden top

- Supplied with 30 hooks (kit 516 SA/K1)

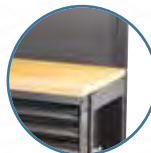

Hooks and LED lamps included

**POSSIBILITY TO INVERT THE DOOR
OPENING DIRECTION**



STEEL

516 SA/CA2

Code U05160236

198 kg | 1.950 mm | 2.000 mm | 650

Steel top
1.450 mm
516 AC/1

Workshop furniture - steel top

- Supplied with 30 hooks (kit 516 SA/K1)

WOOD

516 SA/C2

Code U05160232

190 kg | 1.950 mm | 2.000 mm | 650

Wooden top
1.450 mm
516 SAL/1

Workshop furniture - wooden top

- Supplied with 30 hooks (kit 516 SA/K1)



Hooks, LED lamps and power strips included

DESCRIPTION	ITEM	PCS.
Cabinet with 6 drawers	516 SA/1	1
Cabinet with 2 doors	516 SA/2	1
Pegboard	516 SA/5	6
Raising support	516 SA/11	2
LED lamp	516 SA/12	2
Metal shelf for LED lamp	516 SA/13	2
Fitting kit	516 SA/14	2
Kit of hooks for panels	516 SA/K1	1

DESCRIPTION	ITEM	PCS.
Cabinet with 6 drawers	516 SA/1	1
Cabinet with 2 doors	516 SA/2	1
Cabinet with 1 door	516 SA/3	1
Top chest with tilting door	516 SA/4	2
Pegboard	516 SA/5	3
Pegboard with power strip	516 SA/6	1
Raising support	516 SA/11	3
LED lamp	516 SA/12	2
Fitting kit	516 SA/14	2
Kit of hooks for panels	516 SA/K1	1

IDEAL LAY-OUT

start516-gb.usag.it

POSSIBILITY TO INVERT THE DOOR
OPENING DIRECTION



STEEL

516 SA/CA3
Code U05160237

289 kg | mm | ↔ 2.675
↓ 2.000
↙ 650

Steel top
2.175 mm
516 AC/2

Workshop furniture - steel top

- Supplied with 30 hooks (kit 516 SA/K1)

WOOD

516 SA/C3
Code U05160233

278 kg | mm | ↔ 2.675
↓ 2.000
↙ 650

Wooden top
2.175 mm
516 SAL/2

Workshop furniture - wooden top

- Supplied with 30 hooks (kit 516 SA/K1)

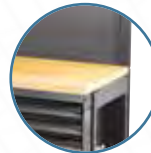

DESCRIPTION	ITEM	PCS.
Cabinet with 6 drawers	516 SA/1	1
Cabinet with 2 doors	516 SA/2	1
Cabinet with 1 door	516 SA/3	1
Top chest with tilting door	516 SA/4	3
Pegboard	516 SA/5	5
Pegboard with power strip	516 SA/6	1
Raising support	516 SA/11	3
LED lamp	516 SA/12	2
Fitting kit	516 SA/14	3
Kit of hooks for panels	516 SA/K1	1
START roller cabinet - 6 drawers (empty)	516 SA/16	1

**Hooks, LED lamps and
power strips included**



STEEL

516 SA/CA4
Code U05160238

160 kg | mm | ↔ 2.175
↓ 2.000
↙ 650

Steel top
2.175 mm
516 AC/2

Workshop furniture - steel top

- Supplied with 30 hooks (kit 516 SA/K1)

WOOD

516 SA/C4
Code U05160234

147 kg | mm | ↔ 2.175
↓ 2.000
↙ 650

Wooden top
2.175 mm
516 SAL/2

Workshop furniture - wooden top

- Supplied with 30 hooks (kit 516 SA/K1)



DESCRIPTION	ITEM	PCS.
Cabinet with 6 drawers	516 SA/1	1
Cabinet with 2 doors	516 SA/2	1
Pegboard	516 SA/5	8
Pegboard with power strip	516 SA/6	1
Raising support	516 SA/11	2
LED lamp	516 SA/12	2
Metal shelf for LED lamp	516 SA/13	3
Fitting kit	516 SA/14	3
Kit of hooks for panels	516 SA/K1	1

**Hooks, LED lamps and power
strips included**

Workbenches

1000 kg



STEEL

6
DRAWERS

3
MODULES

RAL 3020

516 SPC2
Code U05160021

102 kg | mm | → 2.000
↓ 850
↙ 700

START workbench with sheet steel top - 6 drawers (empty)

- Inside dimensions:
3 drawers 570x420x60 mm
2 drawers 570x420x130 mm
1 drawer 570x420x200 mm

RAL 9004

516 SPCN2
Code U05160023

START workbench with sheet steel top - 6 drawers (empty)



2000 mm

Galvanized sheet steel top

Anti-corrosion treated and with 37 mm anti-fall edges.

1000 kg



WOOD

6
DRAWERS

3
MODULES

RAL 3020

516 SPC1
Code U05160020

115 kg | mm | → 2.000
↓ 850
↙ 700

START workbench with wooden top - 6 drawers (empty)

- Inside dimensions:
3 drawers 570x420x60 mm
2 drawers 570x420x130 mm
1 drawer 570x420x200 mm

RAL 9004

516 SPCN1
Code U05160022

START workbench with wooden top - 6 drawers (empty)



2000 mm

Multilayer beech-wood top

The thickness of 40 mm guarantees top resistance.



506 BA

RAL 9004

STEEL

Workbench with sheet steel top

- Galvanized sheet steel top (thickness 2,5 mm) with sides 37 mm
- Lower shelf included
- Arranged for ground fixing
- Enamelled sheet steel structure, black RAL 9004
- 4 brackets for size 1 m and 1,5 m
- 6 brackets for size 2 m
- Possibility to assemble one drawer 506 U130 for model 506 A2/1000 and 506 A2/1500
- Possibility to assemble two drawers 506 U130 for model 506 A2/2000

CODE	L (mm)	P (mm)	H (mm)	Weight
U05060014	1.000	700	850	50 kg
U05060015	1.500	700	850	63 kg
U05060016	2.000	700	850	85 kg

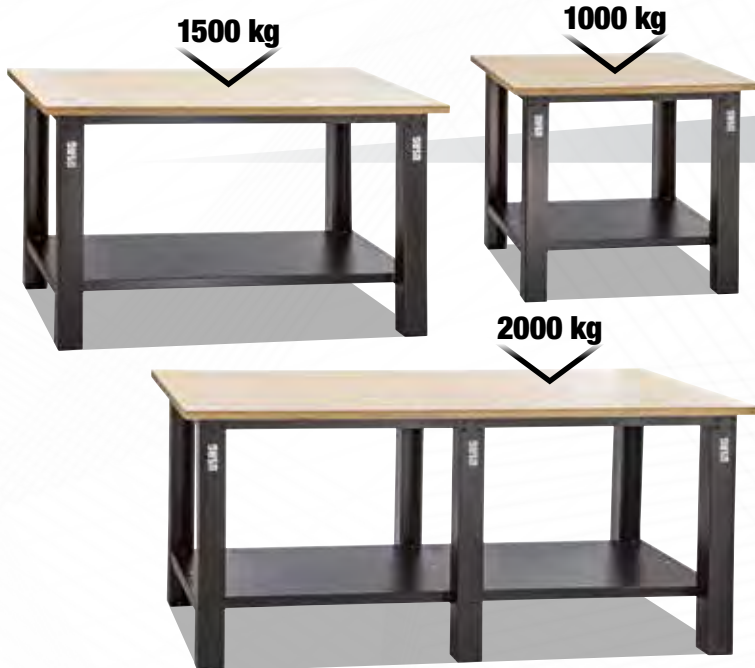

506 BL

RAL 9004

WOOD

Workbench with wooden top

- Multilayer wooden top (thickness 40 mm)
- Lower shelf included
- Arranged for ground fixing
- Enamelled sheet steel structure, black RAL 9004
- 4 brackets for size 1 m and 1,5 m
- 6 brackets for size 2 m
- Possibility to assemble one drawer 506 U130 for model 506 A1/1000 and 506 A1/1500
- Possibility to assemble two drawers 506 U130 for model 506 A1/2000

CODE	L (mm)	P (mm)	H (mm)	Weight
U05060004	1.000	700	850	55 kg
U05060005	1.500	700	850	69 kg
U05060006	2.000	700	850	93 kg



2
DRAWERS

506 BAG/2000

Code U05060034

RAL 9004

STEEL

Workbench with sheet steel top - 2 drawers

- 2 drawers on telescopic slides, with locking
- Structure: black RAL 9004, drawers red RAL 3020
- Inside dimensions of drawers: 570x420x175 mm



2
DRAWERS

506 BLC/2000

Code U05060024

RAL 9004

WOOD

Workbench with wooden top - 2 drawers

- 2 drawers on telescopic slides, with locking
- Structure: black RAL 9004, drawers red RAL 3020
- Inside dimensions of drawers: 570x420x175 mm



THE MODULAR SYSTEM FOR WITH THE CONFIGURATOR YOU CAN EQUIP YOUR VAN AS YOU WANT!

MATRIX

Go to matrixgb.usag.it
or frame the QR code



1 SIMPLE AND INTUITIVE

Place the modules as you like inside your van.

2 IT WORKS ONLINE

No installation required; compatible with the most popular browsers.

3 PROJECT IN A CLICK

Save your project and export it to PDF or Excel to get a quote from your Reseller.



IF YOU WANT, WE CAN CHECK YOUR PROJECT FOR FREE:

Send the excel, Pdf, or .mtx files saved with the configurator at our address matrix@mygts.net.



LAY-OUT OF COMMERCIAL VEHICLES



LEFT SIDE



96 kg | mm | 1.238
1.146
375



5006 EF2
Code U50060035

Composition:

DESCRIPTION	CODE	PCS.
Composition with boxes and drawers 5000 E5	U50000105	1
Composition with drawers 5000 CE3	U50000052	1
Base 5002 B3	U50020010	1
Bottle-holder 5002 SA5	U50020067	1
Uprights 5003 MF1	U50030052	1
Tray-holders 5003 A2/7	U50030074	1
Fixing bar 5002 S5	U50020048	2

Frame the QR code to check the compatible vehicle models



5006 EF4
Code U50060037

Composition:

DESCRIPTION	CODE	PCS.
Base 5002 A2N	U50020004	1
Uprights 5003 MD2	U50030047	1
Uprights 5003 ME2	U50030050	1
Shelf 5003 RA1	U50030024	1
Inclined shelf 5003 RIB2	U50030037	1
Inclined shelf 5003 RIC2	U50030042	2
Fixing system 5002 S5	U50020048	1

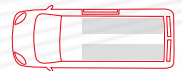

LEFT-RIGHT SIDE



50 kg | mm | 990
1.146
375



Frame the QR code to check the compatible vehicle models



BI-COLOUR FOAM MODULES



519 M 613AEA 519 M 613CEA 519 M 285A1



519 M 127C 519 M 150AX 519 MSK6

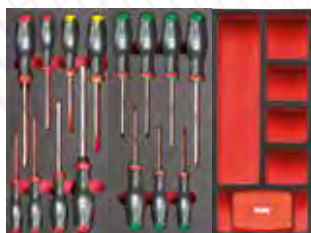

519 M 324H 519 M 324STX 519 MSK6+692 J32

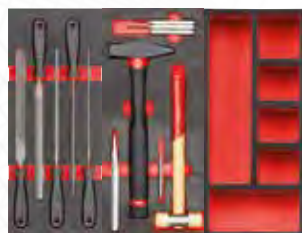

519 M 990A5MD 519 M 382 519 MSK6



519 M 285A1 519 M 324H 519 M 324STX

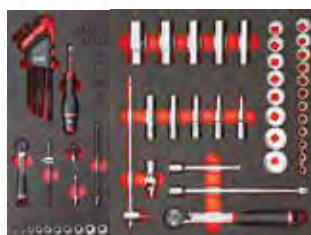

519 M 613AEA 519 M 612CLA



519 M 276C



T-HANDLE WRENCHES

8-10-13-17 mm

495 MB

Code U04950628

156
PIECES



Assortment for MAINTENANCE - 4 drawers

DESCRIPTION	ITEM	PCS.
Hexagonal sockets, ratchet (237 A 1/4"), accessories 1/4" and bits	519 M 613AEA	46
Hexagonal sockets, ratchet (237 A 1/2") and accessories 1/2"	519 M 613CEA	23
Combination wrenches (6-7-8-9-10-11-12-13-14-15-16-17-18-19-21-22-24 mm)	519 M 285A1	17
Pliers for circlips internal and external 15÷25 and 19÷60	519 M 127C	6
Universal pliers, adjustable pliers, cutting nippers, extra-long nose pliers, lock-grip pliers	519 M 150AX	5
Screwdrivers for slot-head and PHILLIPS® screws	519 M 324H	7
Screwdrivers for TORX® Tamper Resistant screws	519 M 324STX	8
Flat square file, half-round file, round file, square file, triangular file (second cut)	519 M 990A5MD	5
Hammer for mechanics with graphite handle, mallet, pin punches, chisel and centre punch	519 M 382F	7
Assortment with bits and reversible ratchet	692 J32	32

495 MAA

Code U04950627

155
PIECES



Assortment for AUTOMOTIVE - 3 drawers

DESCRIPTION	ITEM	PCS.
Hexagonal sockets, ratchet (237 A 1/4"), accessories 1/4" and bits	519 M 613AEA	46
Biexagonal sockets, ratchet (237 A 1/2") and accessories 1/2"	519 M 612CLA	35
Combination wrenches (6-7-8-9-10-11-12-13-14-15-16-17-18-19-21-22-24 mm)	519 M 285A1	17
Screwdrivers for slot-head and PHILLIPS® screws	519 M 324H	7
Screwdrivers for TORX® Tamper Resistant screws	519 M 324STX	8
Pliers for circlips, combination plier, long nose pliers, T-handle wrenches with hex sockets (8-10-13-17 mm), bits set with ratchet	519 M 276C	42



519 M 612CLA 519 M 613BEA 519 M 613AEA

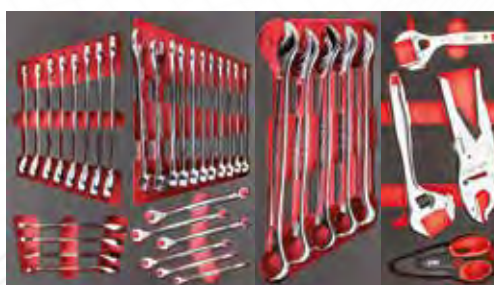

519 M 285KA 519 M 285A1 519 M 285A2 519 M 294B

301
PIECES



495 MC

Code U04950632

Assortment for MAINTENANCE - 4 drawers

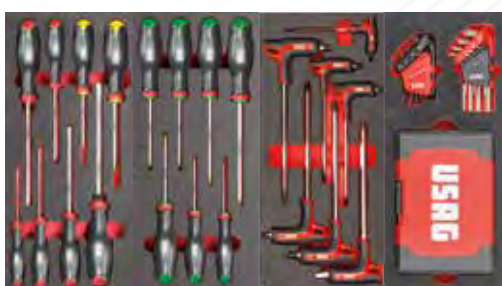

519 M 324H 519 M 324STX 519 M 280HG 519 M 280N1



519 M 127C 519 M 150AX 519 M 382F 519 M 990A5MD



PLASTIC TRAYS



519/613AEA 519/613CEA 519 SK692V



519/285A1 519/150AX 519 SK692V



519/324H 519/324TX 519 SK692V + 692 J32



519 SK692V 519/990A1 519/382F



519/613AEA 519/613CEA 519 SK692V + 692 J32



519/324H 519/285A1 519/150AX

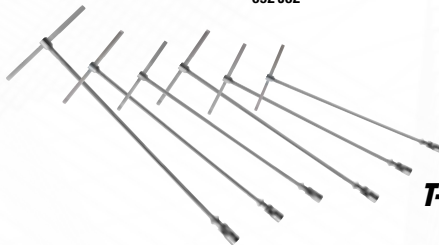

T-HANDLE WRENCHES
7-8-10-12-13-17 mm

495 PM
Code U04950630

157
PIECES



NEW

Assortment for MAINTENANCE - 4 drawers

DESCRIPTION	ITEM	PCS.
Hexagonal sockets, ratchet (237 A 1/4"), accessories 1/4" and bits	519/613AEA	42
Hexagonal sockets, ratchet (237 A 1/2") and accessories 1/2"	519/613CEA	22
Combination wrenches (6-7-8-9-10-11-12-13-14-15-16-17-18-19-22-24 mm) and angled keys (1,5-2-2,5-3-4-5-6-8-10 mm)	519/285A1	25
Universal pliers, adjustable pliers, cutting nippers, extra-long nose pliers, lock-grip pliers	519/150AX	5
Screwdrivers for slot-head and PHILLIPS® screws	519/324H	10
Screwdrivers for TORX® screws	519/324TX	9
Flat square file, half-round file, round file, triangular file (second cut)	519/990A1	4
Hammers, chisels and pin punches	519/382F	8
Assortment with bits and reversible ratchet	692 J32	32

495 PA
Code U04950629

142
PIECES



NEW

Assortment for AUTOMOTIVE

DESCRIPTION	ITEM	PCS.
Hexagonal sockets, ratchet (237 A 1/4"), accessories 1/4" and bits	519/613AEA	42
Hexagonal sockets, ratchet (237 A 1/2") and accessories 1/2"	519/613CEA	22
Screwdrivers for slot-head and PHILLIPS® screws	519/324H	10
Combination wrenches (6-7-8-9-10-11-12-13-14-15-16-17-18-19-22-24 mm) and angled keys (1,5-2-2,5-3-4-5-6-8-10 mm)	519/285A1	25
Universal pliers, adjustable pliers, cutting nippers, extra-long nose pliers, lock-grip pliers	519/150AX	5
T-handle wrenches with jointed hexagonal socket (7-8-10-12-13-17 mm)	276 CE	6
Assortment with Ribe bits with hole - XZN - TORX® Tamper Resistant	692 J32	32

DESCRIPTION	ITEM	PCS.
Hexagonal sockets, ratchet (237 A 1/4"), accessories 1/4" and bits	519 M 613AEA	46
Hexagonal sockets, ratchet (237 A 3/8") and accessories 3/8"	519 M 613BEA	20
Biexagonal sockets, ratchet (237 A 1/2") and accessories 1/2"	519 M 612CLA	35
Reversible ratchet combination wrenches 8-9-10-11-12-13-14-15-16-17-18-19 mm	519 M 285 KA	12
Combination wrenches (6-7-8-9-10-11-12-13-14-15-16-17-18-19-21-22-24 mm)	519 M 285A1	17
Combination wrenches 27-29-30-32-34 mm	519 M 285A2	5
Adjustable wrenches, lock-grip pliers and scissor	519 M 294B	4
Screwdrivers for slot-head and PHILLIPS® screws	519 M 324H	7
Screwdrivers for TORX® Tamper Resistant screws	519 M 324STX	8
Hexagon keys with handgrip (3-4-5-6-7-8-10 mm)	519 M 280HG	7
Set of keys for TORX® screws and assortment of bits with special shapes	519 M 280N1	117
Pliers for circlips internal and external 15÷25 and 19÷60	519 M 127C	6
Universal pliers, adjustable pliers, cutting nippers, extra-long nose pliers, lock-grip pliers	519 M 150AX	5
Flat square file, half-round file, round file, square file, triangular file (second cut)	519 M 990A5MD	5
Hammer for mechanics with graphite handle, mallet, pin punches, chisel and centre punch	519 M 382F	7



CAN'T FIND YOUR IDEAL ASSORTMENT?

Go now to
kitplanner-gb.usag.it
and create it!

Plastic trays



519/127N
Code U05190716 **4** PIECES

127 N 19÷60 · 127 PN 19÷60 ·
128 N 19÷60 · 128 PN 19÷60.



519/150AX
Code U05190850 **5** PIECES

133 AX 160 · 134 250 · 150 AX 180 ·
180 C 250 · 188 AX 160.

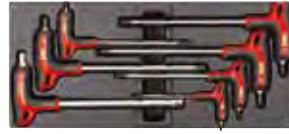

519/280HG
Code U05191860 **7** PIECES

280 HG 3-4-5-6-7-8-10 mm.



519/280HGTS
Code U05191861 **7** PIECES

280 HGTS 3-4-5-6-7-8-10 mm.



519/285A1
Code U05190785 **25** PIECES

285 6-7-8-9-10-11-12-13-14-15-16-17-
18-19-22-24 280 S9 1,5÷10.



519/285B2
Code U05190823 **4** PIECES

285 27-29-30-32.



519/285KA1
Code U05190788 **12** PIECES

285 KA 8-9-10-11-12-13-14-15-
16-17-18-19.



519/294
Code U05190732 **9** PIECES

204 250 · 294 A 250 · 367 2x110-3x130-
4x145-5x165-6x180-8x200 · 981 A3.



519/322H
Code U05190772 **10** PIECES

322 0,5x3x75-0,8x4x100-1x5,5x125-
1,2x6,5x150-1,6x8x175 · 322 PH 0x75-1x100-
2x125 · 322 N 0,8x4x30 · 322 NPH 2x30.



519/322STX
Code U05190831 **6** PIECES

322 STX T10-T15-T20-T25-T30-T40.



519/324H
Code U05190763 **10** PIECES

324 0,5x3x75-0,8x4x100-1x5,5x125-
1,2x6,5x150-1,2x8x200 · 324 PH 0x75-1x75-
2x100 · 324 N 0,8x4x35 · 324 NPH 2x35.



519/324TX
Code U05190764 **9** PIECES

324 TX T6x50-T7x50-T8x50-T9x75 · 324 STX
T10x75-T15x75-T20x100-T25x100-T30x125.



519/366
Code U05190740 **7** PIECES

351 200 · 362 125-150 · 364 125 ·
366 3x125 · 4x150 · 368 4x125.



519/382F
Code U05190742 **8** PIECES

362 150 · 367 2x100-3x130-4x145-
5x165 · 368 4x125 · 376 35 · 382F 500.



519/613AEA  **42** PIECES
Code U05190784 237 A

235 1/4" EN 4-4,5-5-5,5-6-7-8-9-10-11-12-13-
14 · 236 1/4" 50-150 · 237 A 1/4" · 240 1/4" ·
241 1/4" · 243 1/4" · 692 S11 · 692 STX/S11 ·
684 1/4"-1/4".



519/613BEA  **21** PIECES
Code U05190747 237 A

235 3/8" E 6-7-8-9-10-11-12-13-14-15-
16-17-18-19-21-22 · 236 3/8" 125-250 ·
237 A 3/8" · 240 3/8" N · 241 3/8".



519/613CEA  **22** PIECES
Code U05190750 237 A

235 1/2" EN 10-11-12-13-14-15-16-
17-18-19-20-21-22-24-27-30-32 · 236
1/2" 125-250 · 237 A 1/2" · 240 1/2" N
· 241 1/2".



519/990A1
Code U05190825 **4** PIECES

990 M PA/200 · 990 M PB/200
990 M PC/200 · 990 M PE/200.



8 PIECES **XXL**

519/276
Code U05190725
276 CE 7-8-10-11-13-14-17-19.



8 PIECES **XL**

519/280T
Code U05190727
280 T 2-2,5-3-4-5-6-8-10.



CREATE YOUR
This is just a selection of
on kitplanner-gb.usag.it you

Bi-colour foam modules

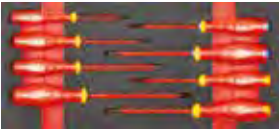

519 M 091A
Code U05191016 **8** PIECES
091 0,5x3x75-0,8x4x100-1x5,5x125
1,2x6,5x150 · 091 PH 1x100-2x125
· 091 PZ 1x100-2x125.



519 M 127N
Code U05190937 **4** PIECES
127 N 19÷60 · 127 PN 19÷60 ·
128 N 19÷60 · 128 PN 19÷60.



519 M 150AX
Code U05190965 **5** PIECES
133 AX 160 · 134 250 · 150 AX 180 ·
180 C 250 · 188 AX 160.



519 M 280HG
Code U05191945 **7** PIECES
280 HG 3-4-5-6-7-8-10 mm.



519 M 280HGTS
Code U05191946 **7** PIECES
280 HGTS 3-4-5-6-7-8-10 mm.



519 M 280N1
Code U05191013 **117** PIECES
280 S9 1,5-2-2,5-3-4-5-6-8-10 · 280 TX/
S8C T10-T15-T20-T25-T27-T30-T40-T45
· 692 J100.



519 M 280TK
Code U05190935 **6** PIECES
280 TK 2,5-3-4-5-6-8.



519 M 285A1
Code U05190921 **17** PIECES
285 6-7-8-9-10-11-12-13-14-15-16-
17-18-19-21-22-24.



519 M 285A2
Code U05190943 **5** PIECES
285 27-29-30-32-34.



519 M 285KA
Code U05190944 **12** PIECES
285 KA 8-9-10-11-12-13-14-15-
16-17-18-19.

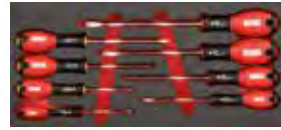

519 M 322H
Code U05190927 **8** PIECES
322 0,5x3x75-0,8x4x100-1x5,5x125-
1,2x6,5x150-1,6x8x175 · 322 PH 0x75-
1x100-2x125.



519 M 322STX
Code U05190929 **6** PIECES
322 STX T10x75-T15x75-T20x100-
T25x100-T30x125-T40x125.



519 M 324H
Code U05190910 **8** PIECES
324 0,5x3x75-0,8x4x100-1x5,5x125-
1,2x6,5x150 · 324 PH 1x100-2x125
324 D 0,6x3,5x100 324 E 1,6x8x175.



519 M 324STX
Code U05190911 **7** PIECES
324 STX T10x75-T15x75-T20x100-
T25x100-T27x100-T30x125-T40x150.



519 M 382F
Code U05190926 **7** PIECES
362 175 · 367 2x100-3x130-6x180
368 3x100 · 376 28 · 382F 500.



519 M 613AEA **46** PIECES
Code U05190940 237 A
235 1/4" EN 5,5-6-7-8-9-10-11-12-13-14
· 236 1/4" 50-100 · 237 A 1/4" · 240 1/4"
· 241 1/4" · 243 1/4" · 280 LTS/S9 · 684
1/4"-1/4" · 660 0,6-1-1,6 · 660 E 3-4-5-6-
8 · 660 PH 1-2-3 · 660 PZ 1-2-3 · 660 STX
T15-T20-T25-T27-T30-T40.



519 M 613BEA **20** PIECES
Code U05190928 237 A
235 3/8" E 7-8-9-10-11-12-13-14-15-16-
17-18-19-21-22 · 236 3/8" 125-250 ·
237 A 3/8" · 240 3/8" N · 241 3/8".



519 M 613CEA **23** PIECES
Code U05190942 237 A
235 1/2" EN 8-10-11-12-13-14-15-16-
17-18-19-21-22-23-24-27-30-32 · 236
1/2" 125-250 · 237 A 1/2" · 240 1/2" N
· 241 1/2".



519 M 990A5MD **5** PIECES
Code U05191011
990 M PA/200 · 990 M PB/200 · 990 M
PC/200 · 990 M PD/200 · 990 M PE/200.

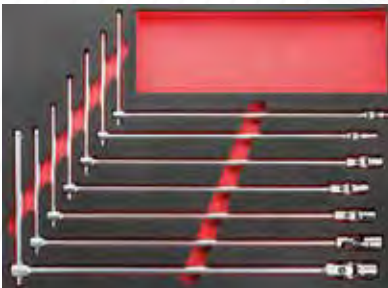

7 PIECES **XXL**
519 M 276
Code U05190936
276 CE 7-8-10-11-13-17-19.

IDEAL ASSORTMENT
the available assortments at Superoffer Conditions:
can find 200 modules and 120 assortments to choose!

Maintenance suitcases



002 JMA
Code U00020011

13 kg | 460 mm | 158 mm | 385 mm

Case with assortment for maintenance

- Case with Aluminium section shell and metal reinforcements
- Double metal closing hinge with lock (key included)
- Three internal panels equipped with elastics to hold tools
- Base with cut-out bi-colour foam



002 JTMA
Code U00020015

14 kg | 485 mm | 200 mm | 377 mm

Tool trolley with assortment for maintenance



**002 JTMA:
WHEELS
INTEGRATED INTO
THE STRUCTURE**



**IT CONTAINS AX SERIES PLIERS,
SCREWDRIVERS 324
AND THE ADJUSTABLE WRENCH 294 AD!**



**181
PIECES**



DESCRIPTION	SIZE	PCS.
Hexagonal sockets 1/2"	10-11-12-13-14-15-16-17-18-19-21-22-24-27-30-32 mm	16
Hexagonal sockets 1/4"	4-4,5-5-5,5-6-7-8-9-10-11-12-13-14 mm	13
Extensions 1/2"	130-250 mm	2
Extensions 1/4"	55-100 mm	2
Reversible ratchet 1/2"		1
Reversible ratchet 1/4"		1
Spinner with handle 1/4"		1
Universal joint 1/2"		1
Universal joint 1/4"		1
Bit-holder socket	1/4-1/4"	1
Combination wrenches	8-9-10-11-12-13-14-15-16-17-18-19 mm	12
Adjustable wrench	250 mm	1
Screwdrivers for slot-head screws	0,4x2,5x50-0,5x3x75-0,8x4x100-1x5,5x125-1,2x6,5x150-1,6x8x175	6
Screwdrivers for PHILLIPS® screws	1x75-2x125	2
Screwdrivers for POZIDRIV®-SUPADRIV® screws	1x75-2x125	2
Angled hexagon keys	1,5-2-2,5-3-4-5-6-8-10 mm	9
Combination pliers	180 mm	1
Adjustable pliers	250 mm	1
Half-round pliers	160 mm	1
Diagonal cutting nippers	160 mm	1

DESCRIPTION	SIZE	PCS.
Phase-testing screwdriver		1
Scissors for electricians		1
Utility knife		1
Tape rule	3 m	1
Mini hacksaw frame		1
Hammer for mechanics	300 g	1
Bits for slot-head screws	3-4-4,5-5-5,5-6-6,5-7-8	9
Bits for PHILLIPS® screws PH	00-0-1(x2)-2(x2)-3-4	8
Bits for POZIDRIV®-SUPADRIV® screws PZ	1-2(x2)-3-4	5
Bits for hex socket screws	1,5-2-2,5-3-4-5-5,5-6-7-8 mm	10
Bits for hex socket screws	1/16-5/64-3/32-7/64-1/8-9/64-5/32-3/16-7/32-1/4	10
TORX® bits	T8-T9-T10-T15-T20-T25-T27-T30-T40-T45	10
TORX® Tamper Resistant bits	T8-T10-T15-T20-T25-T27-T30-T35-T45	9
Tri-Wing bits	1-2-3-4	4
Spanner bits	4-6-8-10-12	5
Torq bits	6-8-10	3
Square bits	0-1-2(x2)-3	5
Clutch bits	1/8-5/32-3/16-1/4-5/16	5
Bits XZN	M5-M6-M8	3
Hexagonal bits for hex socket screws with hole	2-2,5-3-4-5-6	6
Hexagonal bits for hex socket screws with hole	5/64-3/32-7/64-1/8-9/64-5/32	6
Magnetic extensions	1/4"	2



174
PIECES

002 JMP

Code U00020004

Case with assortment for maintenance, inch sizes

- Case with Aluminium section shell and metal reinforcements
- Double metal closing hinge with lock (key included)
- Handle with plastic protection
- Three internal panels equipped with elastics to hold tools
- Blocking system of the folding panel

12 kg | mm | 460 | 155 | 370



1/2" " "

606 1/2 APOL

606 1/4 APOL



692 J100

1/4" " "

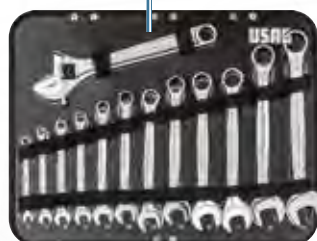

DESCRIPTION	SIZE	PCS.	DESCRIPTION	SIZE	PCS.
Assortment with bihexagonal sockets in ABS case, in inches	606 1/2 APOL	15	Set of 8 long angled hexagon keys with spherical head, inch sizes	280 LTSP/S8	8
Assortment with hexagonal sockets in ABS case, in inches	606 1/4 APOL	18	Combination wrenches, inch sizes	285 P / 1/4-5/16-3/8-7/16-1/2-9/16-5/8-11/16-3/4-13/16-7/8-15/16	12
Phase-testing screwdriver 100÷250V	321 F	1	Adjustable wrenches with quick adjustment	294 AD/250	1
Half-round extra-long nose pliers with straight jaws	133 AX/160	1	Screwdrivers for slot-head screws	324 0,4x2,5x75-0,5x3x75-0,8x4x100-1x5,5x125-1,2x6,5x150-1,6x8x175	6
Combination pliers	150 AX/180	1	Screwdrivers for PHILLIPS® screws	324 PH / 1x75-2x125	2
Box-joint adjustable pliers	180 C/250	1	Screwdrivers for POZIDRIV®-SUPADRIV® screws	324 PZ / 1x75-2x125	2
Heavy-duty diagonal cutting nippers	188 AX /160	1	Hammers for mechanics	382/300	1
Hacksaw frame with blade tensioner	201 S	1	Assortment of bits with special shapes - 1/4"	692 J100	100
Scissors for electricians	207 C	1	Professional tape rule with shockproof covering	981 A/3	1
Utility knife with snap-off blades	220 B1	1			

Portable storage



Shock resistant



Resistant to high and low temperatures

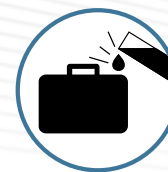

Anti corrosion



001 RV

Code U00010004

Tool case in high thickness polypropilene (empty)

- Two inside removable panels with elastics to hold tools
- Lower compartment with mobile separators
- Double key lock
- Rubber coated ergonomic handle
- Three rear hinges and double metal shaft to hold the cover
- High thickness polypropilene shells assembled on Aluminium frame
- The structure provides resistance to corrosive media, to low and high temperatures and to shocks (even on the corners)

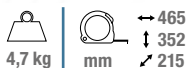

001 TRV

Code U00010005

Tool trolley in high thickness polypropilene (empty)

- Telescopic Aluminium handle
- Wheels with integrated roll bearings



641 T

Tool box (empty)

- High resistant plastic material
- 2 compartments for small objects on the cover
- Possibility to close with a padlock (not supplied)
- Foldaway handle
- Inside removable tray

	CODE	L (mm)	P (mm)	H (mm)	Weight
A	U06410004	16"	394	220	1,2 kg
B	U06410005	19"	486	266	2,1 kg
C	U06410006	24"	595	281	2,8 kg



Opening system with a single hand



Possibility of closure with padlock (not supplied)

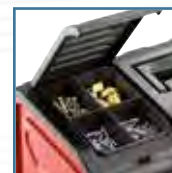

Two compartments for small parts on the cover



5
COMPARTMENTS

646/5LV

Code U06460301

Long cantilever tool box, five compartments (empty)

- Preset for padlock
- Sheet steel casing, anaphoretic process
- Inside dimensions:
lower compartment 537x207x100 mm,
compartments 537x103x52 mm

6,6 kg | mm | 560
320
220



8
COMPARTMENTS

640 A

Code U06400001

Organizer (empty)

- Transparent cover: contents visible
- 8 removable compartments one of which can be further divided with the 2 dividers provided
- Compartments are blocked when cover is closed
- Plastic closing clips

1,5 kg | mm | 422
106
335



5003/1

Plastic tray

	CODE	L (mm)	P (mm)	H (mm)	📐
A	U50030001Q	115	165	75	86 g
B	U50030002Q	160	230	125	180 g
C	U50030003Q	220	340	165	412 g

Portable storage

YouTube

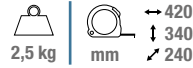

007/1V

Code U00070001

Professional tool bag (empty)

- Model in high strength fabric
- Rigid waterproof bottom
- Inside space for tools
- Aluminium handle with covered handgrip
- 2 front pockets for small objects, 1 side pocket with Velcro closure, 1 side open pocket for quick access to contents, 4 rear pockets protected by the soft top
- 2 internal hooks for tape rule and 6 elastics to hold tools
- 1 pocket with 4 elastics to hold tools and 11 elastics for screwdrivers
- Soft top cover with Velcro



All equipment on hand



007 V

Code U00070002

Professional tool bag - (empty)

- Model in high strength fabric
- Rigid waterproof bottom
- Toolholder compartments and front pocket for a saw
- Aluminium handle with covered handgrip
- Transport shoulder strap
- Soft top cover with Velcro



Front pocket for saw

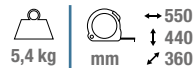

007 TXV

Code U00070065

Trolley tool bag (empty)

- Model in high strength fabric
- Telescopic Aluminium handle
- 6 external pockets and 1 front pocket for a saw
- Toolholder compartments
- Aluminium handle with covered handgrip
- Soft top cover with Velcro
- Maximum loading capacity: 18 kg



Front pocket for saw



Wheels with diameter 90 mm



Telescopic Aluminium handle



Back strap to fix the bag to a trolley



8 compartments and 6 elastic straps for tools



900 g | mm | → 340
↓ 235
↙ 90

007 FTSV

Code U00070060

Folding tool bag (empty)

- High strength fabric
- 8 pockets for tools
- Central internal tool panel with elastics on both sides
- Elastic straps to hold a hammer
- Handle with rubber coating
- Rear belt to fix the bag to a trolley
- Possibility to add a shoulder belt (not included)
- Optional shoulder belt: code U00070001Q



1,8 kg | mm | → 460
↓ 160
↙ 350



007 RV

Code U00070033

Front opening for quick access to content

Bag for laptop and tools (empty)

- High strength fabric
- Rigid reinforced bottom
- Padded compartment for notebook and documents (inside dimensions: 340x240 mm)
- 14 pockets, 2 tool straps and 1 hook for tape rule
- Removable shoulder strap for extra comfort during transport
- Closure with quick release snap buckles



Rear pocket for notebook and documents

007 SV

Code U00070004

Professional backpack (empty)

- High strength fabric
- Adjustable chest strap
- Padded waist straps to distribute the weight evenly
- Rigid waterproof bottom
- Inside tool-holding space
- Side and front pockets
- Inside document holding
- Padded compartment for notebook and documents (inside dimensions: 340x240 mm)

3,1 kg | mm | → 355
↓ 225
↙ 460



Rear pocket for notebook and documents



3,5 kg | mm | → 350
↓ 500
↙ 200

007 TV

Code U00070006

Professional tool trolley (empty)

- Cabin size dimensions
- High strength fabric
- Inside toolholding spaces
- Front document pocket
- Side pockets with straps for long objects
- Telescopic Aluminium handle
- Wheels integrated into the structure
- Back shoulder straps
- Padded compartment for notebook and documents (inside dimensions: 340x240 mm)
- Maximum loading capacity: 14 kg

SCREWDRIVERS 324 TOP PERFORMANCES



THREE-MATERIAL GRIP

- 1 Outside part in polyurethane resistant to oils and chemicals.
- 2 Body in polyamide resistant to the efforts.
- 3 Inside part in high density polyamide for perfect coupling with the blade.

REINFORCED BLADE

Chrome Silicon Vanadium steel that allows the best mechanical resistance.

TOP PERFORMANCE TIP

Zinc finish. Perfect shape. Treatment against corrosion.

ANTI-ROLLING SHAPE

SOFT GRIP COATING
Better comfort during the use.
Greater transmission of the torque.

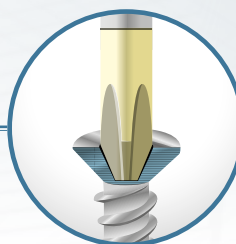
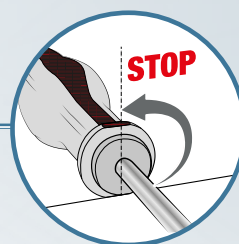

YouTube



324 SH8

Code U03240650

Set of 8 screwdrivers for slot-head and PHILLIPS® screws

- 324 D/0,4x2,5x50
- 324/0,5x3x75-0,8x4x100-1x5,5x125-1,2x6,5x150
- 324 PH/0x75-1x75-2x100

8
PIECES



324 SH5

Code U03240645

Set of 5 screwdrivers for slot-head and PHILLIPS® screws

- 324/0,8x4x100 - 1x5,5x125
- 324 PH/0x75 - 1x75 - 2x100

5
PIECES





12
PIECES

324 SH12

Code U03240651

Set of 12 screwdrivers for slot-head, PHILLIPS® and POZIDRIV® -SUPADRIV® screws



- 324 D/0,4x2,5x50
- 324/0,5x3x75-0,8x4x100-1x5,5x125-1,2x6,5x150
- 324 N/1x5,5x35
- 324 PH/0x75-1x75-2x100
- 324 NPH/2x35
- 324 PZ/1x75-2x100



7
PIECES

324 STX/S7

Code U03240662

Set of 7 screwdrivers for TORX® Tamper Resistant screws



- 324 STX/T10x75-T15x75-T20x100-T25x100-T27x100-T30x125-T40x150



5
PIECES

324 L/SH5

Code U03240422

Set of 5 screwdrivers for slot-head screws



- 324 L 0,6x3,5x250-0,8x4x300-1x5,5x300.
- 324 LPH 1x250-2x250.



COMBIDRIVE 333 K NEW DESIGN OF THE HANDLE.



YouTube

8

PIECES

NEW

333 K/SH8

Code U03330142



COMBIDRIVE set with bits

- 3in1 COMBIDRIVE handle: ratchet screwdriver, T wrench and stubby screwdriver
- Magnetic bits holder included
- Delivered with 6 different bits 1/4"

DESCRIPTION	ITEM/SIZE	PCS.
COMBIDRIVE handgrip with 3 functions 333 K		1
COMBIDRIVE magnetic bit-holder 333 1/4 MG		1
Bits for slot-head screws -1/4"	660/0,6x4,5-1x5,5	2
Bits for PHILLIPS® screws -1/4"	660 PH 1-2	2
Bits for hex socket screws -1/4"	660 E 3-4	2



1/4

333 K/SB10

Code U03330143



COMBIDRIVE set in nylon bag

- 3in1 COMBIDRIVE handle: ratchet screwdriver, T wrench and stubby screwdriver
- Magnetic bits holder included
- Delivered with 8 different blades
- Nylon bag with belt hook

DESCRIPTION	ITEM/SIZE	PCS.
COMBIDRIVE handgrip with 3 functions 333 K		1
COMBIDRIVE magnetic bit-holder 333 1/4 MG		1
Reversible COMBIDRIVE blades for slot-head screws 333 I 0,6x3,5-0,8x4/1x5,5-1,2x6,5		2
Reversible COMBIDRIVE blades for PHILLIPS® screws 333 PH 0-1/2-3		2
Reversible COMBIDRIVE blades for TORX® screws 333 TX T8-T9/T10-T15/T20-T25/T30-T40		4



1/4

USAG 660 bits
not included

10
PIECES

NEW

333 K/SC23

Code U03330149



COMBIDRIVE set in plastic case

- 3in1 COMBIDRIVE handle: ratchet screwdriver, T wrench and stubby screwdriver
- Magnetic bits holder and sockets holder included
- Delivered with 12 different blades and 8 bits 1/4"
- ABS case with internal bi-colour foam

DESCRIPTION	ITEM/SIZE	PCS.
COMBIDRIVE handgrip with 3 functions	333 K	1
COMBIDRIVE sockets holder	333 1/4 Q	1
COMBIDRIVE magnetic bit-holder	333 1/4 MG	1
Reversible COMBIDRIVE blades for hex socket screws	333 E 2,5-3-4-5-6	5
Reversible COMBIDRIVE blades for PHILLIPS® screws	333 PH 0-1/2-3	2
Reversible COMBIDRIVE blades for slot-head screws	333 I 1x5,5-1,2x6,5	1
Reversible COMBIDRIVE blades for TORX® screws	333 TX T8-T9 - 333 STX T10-T15/T20-T25/T30-T40	4
Bits for slot-head screws -1/4"	660 0,6x4,5-1x5,5-1,2x6,5-1,6x8	4
Bits for POZIDRIV® - SUPADRIV® screws -1/4"	660 PZ 0-1-2-3	4



1/4

23
PIECES

NEW

SCREWDRIVERS 322

QUALITY AND CONVENIENCE.



322 SH7
Code U03220254

Set of 7 screwdrivers for slot-head and PHILLIPS® screws

- 322/0,4x2x50-0,5x3x75-0,8x4x100-1x5,5x100-1,2x6,5x150
- 322 PH/1x100-2x125



322 SH10
Code U03220255

Set of 10 screwdrivers for slot-head, PHILLIPS® and POZIDRIV® screws

- 322/0,4x2x50-0,5x3x75-0,8x4x100-1x5,5x100-1,2x6,5x150
- 322 PH/0X75-1x100-2x125
- 322 PZ/1X100-2X125

SCREWDRIVERS 091

1000V INSULATION - EN 60900.

USAG SLIM



091 D/SH5
Code U00910119

Set of 5 SLIM screwdrivers for slot-head and PHILLIPS® screws - 1000 V

- 091 D/0,6x3,5x100-0,8x4x100-1x5,5x125
- 091 DPH/1x100-2x125



091 SH5
Code U00910100

Set of 5 screwdrivers for slot-head and PHILLIPS® screws - 1000 V

- 091/0,5x3x75-0,8x4x100-1x5,5x125
- 091 PH/1x100-2x125



091 SH8
Code U00910106

Set of 8 screwdrivers for slot-head and PHILLIPS®, POZIDRIV® - SUPADRIV® screws - 1000 V

- 091/0,5x3x75-0,8x4x100-1x5,5x125-1,2x6,5x150
- 091 PH/1x100-2x125
- 091 PZ/1x100-2x125

Hexagonal keys and bits

YouTube



32
PIECES



280 g | mm | 138
30
98



692 J32

Code U06920042

Assortment with bits and reversible ratchet - 1/4"

DESCRIPTION	SIZE	PCS.
Bits for slot-head screws	4-5,5-6,5-8	4
Bits for PHILLIPS® screws PH	PH 1-2-3	3
Bits for POZIDRIV® screws PZ	PZ 1-2-3	3
Bits for hex socket screws	3-4-5-6	4
TORX® bits	T8-10-15-20-20-25-25-30-40	9
TORX® Tamper Resistant bits	STX 10-15-20-25-27-30-40	7
Magnetic reversible ratchet		1
Ratchet		1



49
PIECES



280 g | mm | 138
30
98



692 J49

Code U06920041

Assortment with bits - 1/4"

DESCRIPTION	SIZE	PCS.
Bits for slot-head screws	4-4,5-5,5-6,5-6,5-8	6
Bits for PHILLIPS® screws PH	PH 1-1-2-2-2-3	6
Bits for POZIDRIV® screws PZ	PZ 1-1-2-2-2-3-3	7
Bits for hex socket screws	2-3-3-4-4-5-5-6-6	9
TORX® bits	TX 10-10-15-15-20-20-25-25-30-30	10
TORX® Tamper Resistant bits	STX 10-15-15-20-20-25-25-30-30-40	10
Magnetic bit-holder adapter		1

664 S25

Code U06640111

25
PIECES



800 g | mm | 215
45
150

Assortment with long bits for impact wrenches - 1/4"

- Plastic box
- Base with foam cut-out
- Bits size and shape marked on the base
- Direct fitting for electric and pneumatic tools
- Magnetic bit-holder adapter included

DESCRIPTION	SIZE	PCS.
Bits for slot-head screws	3-4-5-6	4
Bits for PHILLIPS® screws	1-2(x2)-3(x1)	5
Bits for POZIDRIV® screws	1-2(x2)-3(x1)	5
Bits for TORX® screws	T15-T20-T25-T30-T40	5
Bits for hex socket screws	2-3-4-5-5,5	5
Magnetic bit-holder adapter		1



Colour code for quick identification of the bit

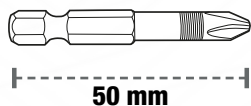

664 B/S7

Code U06640015

Assortment with magnetic socket bits for hexagonal screws 1/4"

- Compact plastic box
- Base with foam cut-out
- Direct fitting for electric and pneumatic tools
- Hexagonal opening with magnet inside
- Magnetic socket bits: sizes 5,5-6-7-8-10-12-13 mm



7
PIECES



5,5-6-7-8
10-12-13 mm

300 g | mm | 138
30
98



Hexagonal keys and bits



900 g | 215 mm
45 mm | 150

DESCRIPTION	SIZE	PCS.
Bits for slot-head screws	3-4-4,5-5-5,5-6-6,5-7-8	9
Bits for screws	PH 00-0-1-1-2-2-3-4 PZ 1-2-2-3-4	13
Bits for hex socket screws	1,5-2-2,5-3-4-5-5,5-6-7-8 mm 1/16-5/64-3/32-7/64-1/8-9/64-5/32-3/16-7/32-1/4"	20
TORX® bits	T 8-9-10-15-20-25-27-30-40-45	10
TORX® Tamper Resistant bits	STX 8-10-15-20-25-27-30-35-40	9
Tri-Wing bits	1-2-3-4	4
Spanner bits	4-6-8-10-12	5
Torq-set bits	6-8-10	3
Square bits	0-1-2-2-3	5
Clutch bits	1/8-5/32-3/16-1/4-5/16	5
Bits XZN	M5-M6-M8	3
Bits for hex socket screws with holes	2-2,5-3-4-5-6 mm - 5/64-3/32-7/64-1/8-9/64-5/32"	12
Magnetic bit-holder adapter	1/4x60mm	2

692 J100

Code U06920043

Assortment of bits with special shapes - 1/4"

100
PIECES

1/4



COMPACT SUPPORTS WITH QUICK EXTRACTION SYSTEM



Watch the video



YouTube



9
PIECES

280 LTS/S9

Code U02800084

Set of 9 long angled hexagon keys with spherical head

• 280 LTS/1,5-2-2,5-3-4-5-6-8-10 mm



8
PIECES

280 LTSTX/S8

Code U02800078

Set of 8 long angled keys with spherical head for TORX® screws

• 280 LTSTX/T10-T15-T20-T25-T27-T30-T40-T45



9
PIECES

280 XLTS/S9

Code U02800184

Set of 9 long hexagon keys with spherical head

• 280 XLTS/1,5-2-2,5-3-4-5-6-8-10 mm



Hexagonal keys and bits



YouTube

KEY 280 T GUARANTEED SAFETY



**SPECIAL CHROME
VANADIUM STEEL**



USAG KEY



OTHER KEYS

GUARANTEED SAFETY

- + 30% resistance to torsion compared to ISO 2936 rules.
- When the breaking torque is reached, the key will deform without breaking.



FIX BAR

Maximum resistance.

**7
PIECES**



280 T/SE7
Code U02800903

Set of 7 T-handle hexagon keys

- 280 T/2-2,5-3-4-5-6-8 mm

**8
PIECES**



280 TTX/SE8
Code U02800686

Set of 8 T-handle keys for TORX® screws

- 280 TTX/T6-T7-T8-T9-T10-T15-T20-T25

**6
PIECES**



280 TTS/SE6
Code U02800760

Set of 6 T-handle hexagon keys with spherical head

- 280 TTS/2,5-3-4-5-6-8 mm

**6
PIECES**



280 TK/SE6
Code U02800020

Set of 6 T-handle hexagon keys with sliding bar

- 280 TK/2,5-3-4-5-6-8 mm



**Spherical
head**



**Sliding
bar**

ANGLED HEXAGON KEYS 280 HG WITH HANDGRIP



GUARANTEED SAFETY

- + 30% resistance to torsion compared to ISO 2936 rules.
- When the breaking torque is reached, the key will deform without breaking.

Same blade as the 280 T keys



ERGONOMIC BIMATERIAL HANDGRIP

SPECIAL CHROME VANADIUM STEEL

6
PIECES



280 HG/SE6
Code U02801460

Set of 6 angled hexagon keys with bimaterial handgrip

- 280 HG/2,5-3-4-5-6-8



6
PIECES



280 HGTS/SE6
Code U02801463

Set of 6 angled hexagon keys with spherical head and bimaterial handgrip

- 280 HGTS/2,5-3-4-5-6-8 mm

6
PIECES



280 HAP/SE6
Code U02800462

Set of 6 angled hexagon keys with handgrip, inch sizes

- 280 HAP/1/4-7/32-5/32-5/16-3/8-3/16

6
PIECES



280 HATX/SE6
Code U02800464

Set of 6 angled keys with handgrip for TORX® screws

- 280 HATX/T8-T10-T15-T20-T25-T30

RANGE OF PLIERS "AX" CHROME PLATED FINISH. BIMATERIAL HANDLES.



Can cut up to 2 mm piano wire with 30% less effort in comparison to the maximum value stated on the European rules ISO5749 (cutting nippers) - ISO5746 (pliers)

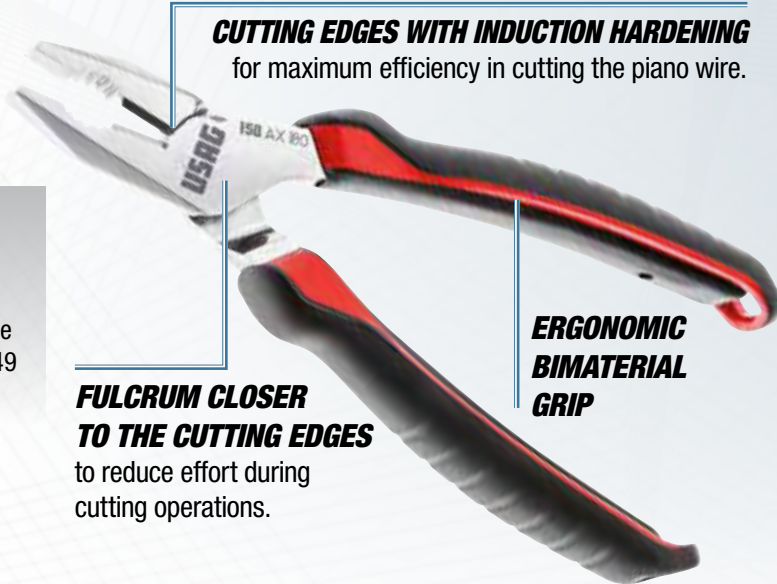

CUTTING EDGES WITH INDUCTION HARDENING
for maximum efficiency in cutting the piano wire.

FULCRUM CLOSER TO THE CUTTING EDGES
to reduce effort during cutting operations.

ERGONOMIC BIMATERIAL GRIP

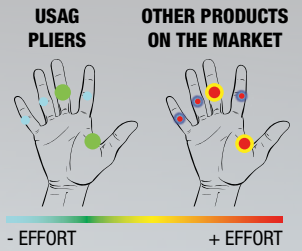

- EFFORT + EFFORT

Minimum effort resulting from the studies on muscle strain made by the prestigious US Ergonomics Institute

3
PIECES



150 AX/SE3
Code U01500201

Assortment with combination pliers, extra-long half-round nose pliers and cutting nippers

- Combination pliers 150 AX 180
- Half-round extra-long nose pliers with straight jaws 133 AX 160
- Diagonal cutting nippers 188 AX 160

3
PIECES



1000 V

085 EX/SE3
Code U00850121

Assortment with combination pliers, half-round nose pliers with straight jaws and diagonal cutting nippers - 1000 V

- Half-round extra-long nose pliers with straight jaws 081 EX 160
- Combination pliers 085 EX 180
- Diagonal cutting nippers 087 EX 160



ROUND PROFILES
Special notch on the toothing for a strong grip of round bars, also threaded

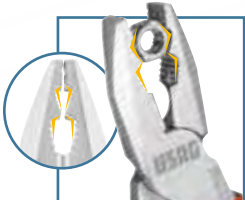

HEXAGONAL PROFILES
Jaw shape studied to grip hexagonal material



155 AX
Code U01550001

Multifunction combination pliers

Multifunction combination pliers

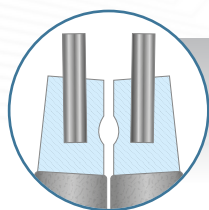

MAXIMUM RESISTANCE

Spring steel tips inserted into the nose.

4

PIECES



4

PIECES



127 N/SE4S

Code U01270046

Set of 4 pliers for circlips

- Pliers for internal circlips **127 N** 12÷25, **127 PN** 12÷25, pliers for external circlips **128 N** 10÷25, **128 PN** 10÷25

Small sizes

127 N/SE4

Code U01279000P

Set of 4 pliers for circlips

- Pliers for internal circlips **127 N** 19-60, **127 PN** 19-60, pliers for external circlips **128 N** 19-60, **128 PN** 19-60

Large sizes

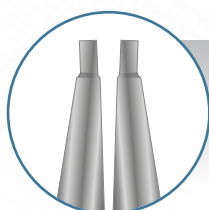

MAXIMUM ACCESSIBILITY

Nose and tip in a single body.

4

PIECES



4

PIECES



127 C/SE4S

Code U01270045

Set of 4 pliers for circlips

- Pliers for internal circlips **127 C** 12÷25, **127 CP** 12÷25, pliers for external circlips **128 C** 10÷25, **128 CP** 10÷25

Small sizes

127 C/SE4

Code U01270040

Set of 4 pliers for circlips

- Pliers for internal circlips **127 C** 19-60, **127 CP** 19-60, pliers for external circlips **128 C** 19-60, **128 CP** 19-60

Large sizes

PLIER WRENCH 174 CX PLIER AND WRENCH IN THE SAME TOOL



YouTube



QUICK ADJUST CLOSING
without pushing the button.

MAX. CAPACITY
58 mm

METRIC SCALE

20 POSITIONS RAIL

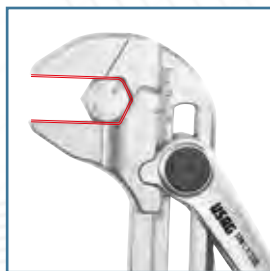

NEW

PARALLEL JAWS
Internal design that fits perfectly
the hexagon.



FLAT JAWS

**PVC COVERED
HANDLES**

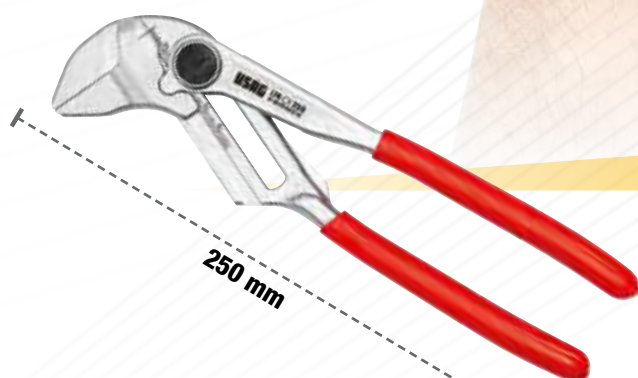

174 CX
Code U01740001

Adjustable plier wrench

NEW

LARGE OPENING CAPACITY +20%

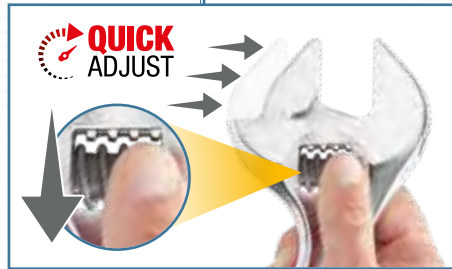

**QUICK ADJUSTMENT
BY PULLING BACK THE ROLL**

**PRECISE REGULATION
BY ROTATING THE ROLL**

294 AD

Adjustable wrenches with quick adjustment

- Quick adjustment by pulling back the roll
- Large capacity: opening +20% compared to the standard
- Double graduated scale: millimetres and inches
- Head angled at 22°
- Steel roll
- Hanging hole
- Chrome plated finish

CODE	L	OPENING
U02940011	110 mm - 4"	17 mm
U02940012	150 mm - 6"	23 mm
U02940013	200 mm - 8"	33 mm
U02940014	250 mm - 10"	38 mm
U02940015	300 mm - 12"	41 mm
U02940016	380 mm - 15"	50 mm
U02940017	460 mm - 18"	63 mm

LARGE OPENING CAPACITY +20%

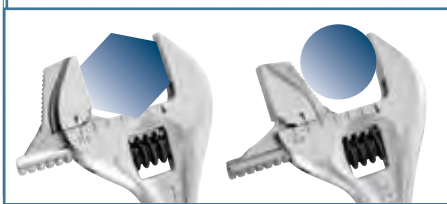

**STANDARD
POSITION**

**REVERSED
JAW**

**REVERSE THE
MOVABLE JAW**
to drive an hexagonal
or a round profile

294 AG

Reversible adjustable wrenches with handle

- In the standard position it can drive a hexagonal profile
- By reversing the movable jaw, it can drive a round profile
- Large capacity: opening +20% compared to the standard
- Double graduated scale: millimetres and inches
- Ergonomic bimaterial handle
- Head angled at 22°
- Steel roll
- Hanging hole
- Chrome plated finish

CODE	L	OPENING
U02940023	200 mm - 8"	33 mm
U02940024	250 mm - 10"	38 mm
U02940025	300 mm - 12"	41 mm



294 AC

Code U02940010

Short adjustable wrench

- Length reduced of 46% compared to a standard wrench
- Same jaw opening of a 12" wrench
- Lightweight and compact for optimum accessibility
- Regulation by steel roll
- Scale in millimeters on the wrench head
- Chrome plated finish



**LENGTH REDUCED OF
46% COMPARED TO A
STANDARD WRENCH**

COMBINATION WRENCH 285 RESISTANCE AND ERGONOMIC.

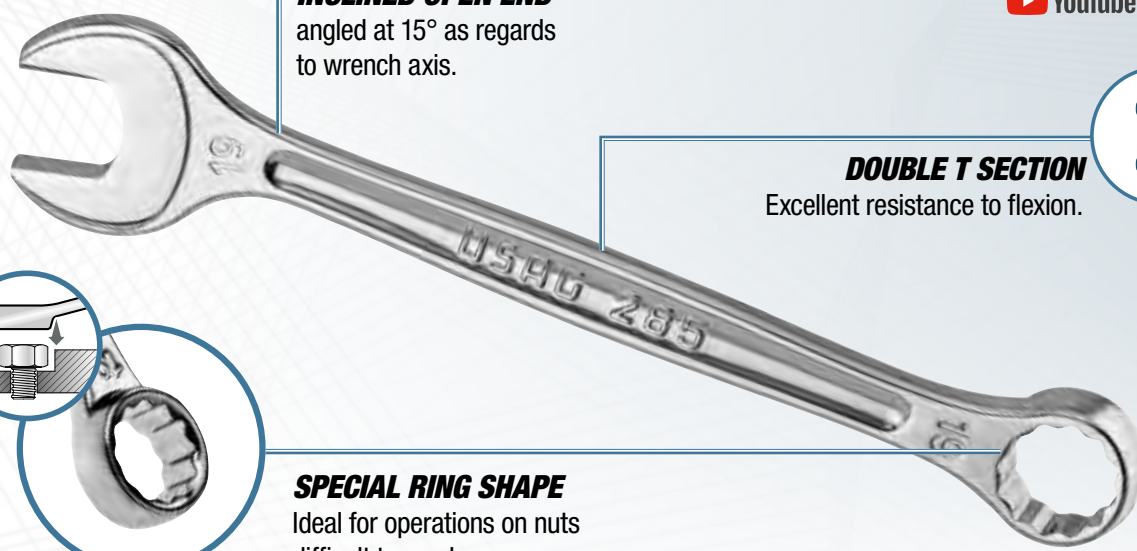

INCLINED OPEN END
angled at 15° as regards to wrench axis.

DOUBLE T SECTION
Excellent resistance to flexion.



SPECIAL RING SHAPE
Ideal for operations on nuts difficult to reach.

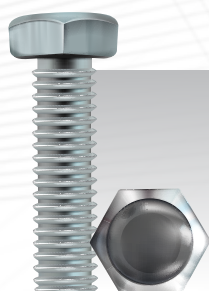

TOP PERFORMANCE

The open end and the bihexagonal ring of the combination wrench 285 exceed the static torsion test, **reaching a torque of + 50% compared to the test value required by the standard ISO 1711-1**

**ISO 1711-1
SAE AS 954E**



**8
PIECES**

8÷19 mm



**26
PIECES**

6÷32 mm

285 DS8

Code U02850863

Set of 8 combination wrenches

- 285/8-10-11-12-13-14-17-19 mm
- Supplied with plastic holder

285 SE26

Code U02850861

Set of 26 combination wrenches

- 285/6-7-8-9-10-11-12-13-14-15-16-17-18-19-20-21-22-23-24-25-26-27-28-29-30-32 mm

REVERSIBLE RATCHET COMBINATION WRENCHES 285 KA WITH LOCKING RING.

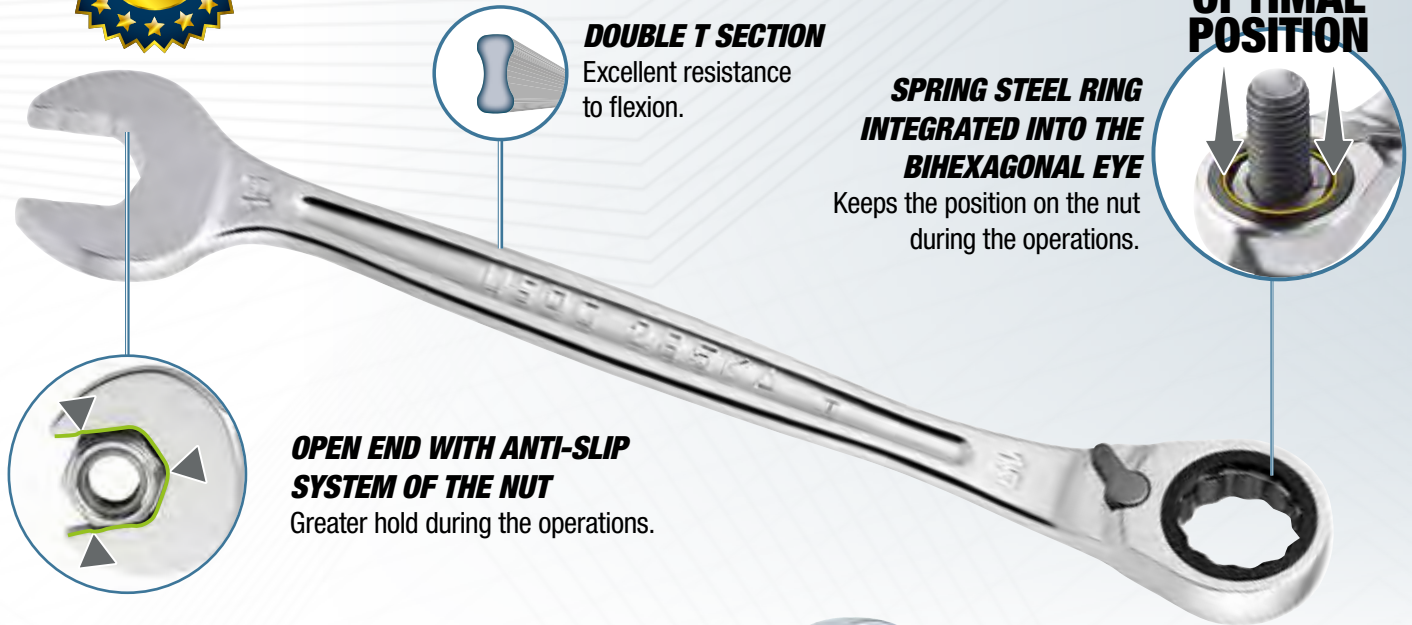

DOUBLE T SECTION
Excellent resistance to flexion.

OPTIMAL POSITION



SPRING STEEL RING INTEGRATED INTO THE BIHEXAGONAL EYE
Keeps the position on the nut during the operations.



OPEN END WITH ANTI-SLIP SYSTEM OF THE NUT
Greater hold during the operations.

STRONG RATCHET

The ratcheting ring of USAG wrenches 285 KA exceeds static torsion tests, reaching a torque of +50% compared to the value required by ISO rules 1711-1



YouTube

8
PIECES

8÷19 mm



285 KA/DS8

Code U02856058

Set of 8 reversible ratchet combination wrenches with locking ring

- 285 KA 8-10-11-12-13-14-17-19 mm

12
PIECES

7÷19 mm



285 KA/DS12

Code U02856062

Set of 12 reversible ratchet combination wrenches with locking ring

- 285 KA 7-8-10-11-12-13-14-15-16-17-18-19 mm

Wrenches

8
PIECES

8÷19 mm

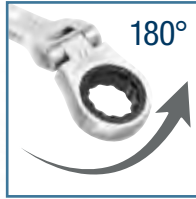

JOINTED HEAD



285 KF/DS8

Code U02856158

Set of 8 hinged jointed ratchet combination wrenches

- 285 KF/8-10-11-12-13-14-17-19 mm

8
PIECES

8÷19 mm



**CHANGE OF ROTATION
DIRECTION**



285 KB/SR8

Code U02856339

Set of 8 flat ratchet combination wrenches

- 285 KB/8-10-12-13-14-15-17-19 mm

4
PIECES

22÷30 mm



285 L/SE4

Code U02850340

Set of 4 long combination wrenches

- 285 L/22-24-27-30 mm.

8
PIECES

6÷22 mm



252 N/SR8

Code U02520862

Set of 8 double ended open jaw wrenches

- 252 N/6x7-8x9-10x11-12x13-14x15-16x17-18x19-20x22 mm

4
PIECES

7÷13 mm



299 SE4

Code U02990200

Set of 4 socket spinners with grip

- 299/7-8-10-13 mm

8
PIECES

7÷19 mm

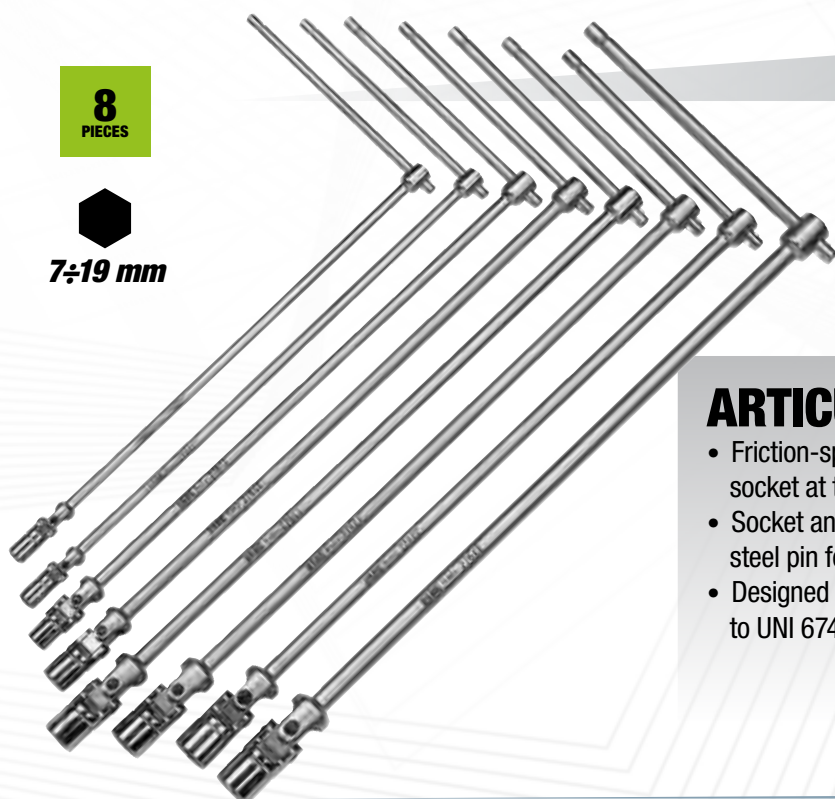

276 CE/SE8

Code U02760484

Set of 8 T-handle wrenches with jointed hexagonal socket

- 276 CE/7-8-10-12-13-14-17-19 mm

ARTICULATED JOINT

- Friction-spring to allow presetting of the socket at the desired angle
- Socket and joint are fixed with a riveted steel pin for great stability.
- Designed and manufactured according to UNI 6743 rules.



REVERSIBLE RATCHET 237 A WITH SEALED MECHANISM IP51.



Inversion system integrated into the cover



Head thickness reduced, compared to standard models



YouTube



CONICAL HANDLE
in anti-slip bimaterial.

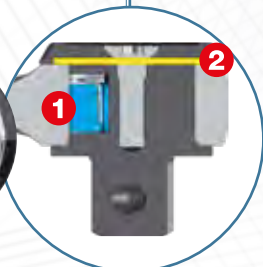

1. New patented pawl
2. Protective diaphragm

TOP PERFORMANCE

1. Static torsional resistance:
+30% compared to the value required by ISO 3315 rules, with the patented pawl.
2. Effort resistance:
assures twice the tightening cycles compared to standard products on the market, with IP51 protection.



23
PIECES

1 1/2"



3 kg | 330 mm | 60 | 215

606 1/2" EA
Code U06060302

Assortment with hexagonal sockets in ABS case

- High resistance ABS case with quick closing system
- The inside tray is studied to be stored in USAG roller cabinet drawers
- Empty inner plastic tray: code U06060300Q



19
PIECES

1 1/4"



1 kg | 210 mm | 60 | 130

606 1/4" EA
Code U06060101

Assortment with hexagonal sockets in ABS case

- High resistance ABS case with quick closing system
- The inside tray is studied to be stored in USAG roller cabinet drawers
- Empty inner plastic tray: code U06060100Q

DESCRIPTION	ITEM/SIZE	PCS.
Hexagonal sockets	235 1/2 EN 8-9-10-11-12-13-14-15-16-17-18-19-21-22-23-24-27-30-32	19
Extensions	236 1/2 125-250	2
Universal joint	241 1/2	1
Reversible ratchet with sealed mechanism (certified IP51)	237 A 1/2	1

DESCRIPTION	ITEM/SIZE	PCS.
Hexagonal sockets	235 1/4 EN 4-4,5-5-5,5-6-7-8-9-10-11-12-13-14	13
Extensions	236 1/4 50-100	2
Universal joint	241 1/4	1
T-handle with sliding square drive	240 1/4	1
Spinner with handle	243 1/4	1
Reversible ratchet with sealed mechanism (certified IP51)	237 A 1/4	1

RATCHET 237 D WITH SLIDING SQUARE DRIVE

60 THEET MECHANISM
with 6° working angle.

NEW

CONICAL HANDLE
in anti-slip bimaterial.

SLIDING SQUARE

Pushing the square drive and turning the ratchet at 180°, you can inverse the working sense.

237 D

ITEM	CODE	□	L (mm)
237 D 1/4"	U02370053	1/4"	125
237 D 3/8"	U02370055	3/8"	200
237 D 1/2"	U02370057	1/2"	260



15
PIECES

1/2"



NEW



12
PIECES

1/4"



NEW

604 1/2" ED
Code U06040300

2 kg | 330 mm | 60 | 215

Assortment with hexagonal sockets in ABS case

- High resistance ABS case with quick closing system
- The inside tray is studied to be stored in USAG roller cabinet drawers
- Empty inner plastic tray: code U06040300Q

DESCRIPTION	ITEM/SIZE	PCS.
Hexagonal sockets	235 1/2 EN 10-11-12-13-14-15-16-17-18-19-21-22-24	13
Extension	236 1/2 125	1
Ratchet with sliding square drive	237 D 1/2	1

605 1/4" ED
Code U06050100

600 g | 210 mm | 60 | 130

Assortment with hexagonal sockets in ABS case

- High resistance ABS case with quick closing system
- The inside tray is studied to be stored in USAG roller cabinet drawers
- Empty inner plastic tray: U05190738Q

DESCRIPTION	ITEM/SIZE	PCS.
Hexagonal sockets	235 1/4 EN 5,5-6-7-8-9-10-11-12-13	9
Extension	236 1/4 100	1
Ratchet with sliding square drive	237 D 1/4	1
Spinner with handle	243 1/2	1

Ratchets and sockets



38
PIECES

1/4"



900 g | mm | 155
50
95

609 1/4" EB

Code U06090002



Assortment with hexagonal sockets and bits in bimaterial box

- Compact bimaterial box with soft-touch covering
- Metal closing clip
- Socket size engraved inside
- Compact dimensions: 30% less bulky than the standard boxes

DESCRIPTION	ITEM/SIZE	PCS.
Hexagonal sockets	235 1/4" EN 5,5-6-7-8-9-10-11-12-13-14 mm	10
Extensions	236 1/4" 50-100	2
Reversible ratchet with sealed mechanism	237 B 1/4"	1
Universal joint	241 1/4"	1
Spinner with handle	243 1/4"	1
Bits for slot-head screws -1/4"	660 0,6x4,5-1x5,5-1,2x6,5	3
Bits for PHILLIPS® screws -1/4"	660 PH 1-2-3	3
Bits for POZIDRIV® - SUPADRIV® screws -1/4"	660 PZ 1-2-3	3
Bits for hex socket screws -1/4"	660 E 2-3-4-5-6	5
Bits for TORX® Tamper Resistant screws -1/4"	660 STX T10-T15-T20-T25-T27-T30-T40	7
Socket-holder bit -1/4"	660 Q 1/4"	1
Bit-holder sockets	684 1/4"-1/4"	1



YouTube



Socket-holder

31
PIECES

1/4"



350 g | mm | 120
35
65



606 1/4" SK

Code U06060012

Assortment with bits and reversible ratchet

DESCRIPTION	ITEM/SIZE	PCS.
Reversible ratchet	237 1/4" SFK	1
Bits for slot-head screws -1/4"	660 0,5x4-1x5,5	2
Bits for hex socket screws -1/4"	660 E 1,5-2-2,5-3-4-5-6-7-8	9
Bits for PHILLIPS® screws -1/4"	660 PH 1-2-3	3
Bits for POZIDRIV® - SUPADRIV® screws -1/4"	660 PZ 1-2-3	3
Socket-holder bit -1/4"	660 Q 1/4"	1
Bits for TORX® Tamper Resistant screws -1/4"	660 STX T10-T15-T20-T25-T27-T30-T40	7
Bits for TORX® screws -1/4"	660 TX T6-T7-T8-T9	4
Magnetic bit-holder adapter - 1/4"	672 1/4" MG 100	1



YouTube



11
PIECES

1/4"

11 mm

265 g | mm | 120
35
65

5,5-6-7-8-9-10-11-12-13-14 mm

610 1/4" EFK

Code U06100001

Assortment with short hexagonal sockets and reversible ratchet in bimaterial box

SHORT HEXAGONAL SOCKETS

They offer more accessibility also using a standard ratchet.

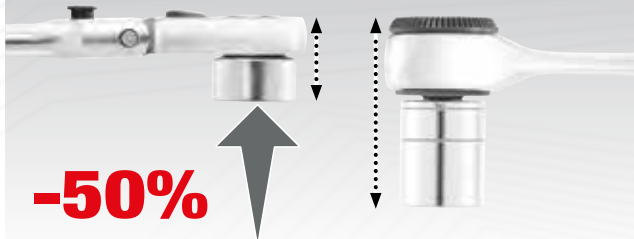

-50%

THE TOP FOR HARD TO REACH AREAS



608 1/4" EAK
Code U06080305

↔ 435
↑ 70
mm ↓ 270

50
PIECES

1/4"



Assortment with hexagonal sockets in ABS case

- High resistance ABS case with quick closing system
- The inside tray is studied to be stored in USAG roller cabinet drawers
- Empty inner foam module: code U05191020Q

DESCRIPTION	ITEM/SIZE	PCS.
Hexagonal sockets	235 1/4 EN 4-4,5-5-5,5-6-7-8-9-10-11-12-13-14	13
Reversible ratchet with revolving handle	237 1/4 AK	1
Spinner with handle	243 1/4	1
Flexible spinner with handle	243 1/4 SN	1
T-handle key with jointed square drive	273 1/4 Q	1
Assortment with bits and reversible ratchet (31 pcs.)	606 1/4 SK	31
Adapter	247 1/4	1
Bit-holder sockets	684/1	1



T-handle key with jointed square drive



Flexible spinner with handle



Reversible ratchet with revolving handle



Hinged ratchet for bits

REVERSIBLE RATCHET WITH REVOLVING HANDLE

1/4"

237 1/4" AK
Code U02370003

Reversible ratchet with revolving handle



1/2"

237 1/2" AK
Code U02370009

Reversible ratchet with revolving handle



612 3/4" EB
Code U06120017



13 kg | mm ↔ 425
↑ 83
↙ 395

17
PIECES

3/4"



Assortment in sheet steel box with hexagonal sockets

DESCRIPTION	ITEM/SIZE	PCS.
Hexagonal sockets	235 3/4 N 22-23-24-26-27-28-30-32-36-38-41-46-50	13
Extensions	236 3/4 200-400	2
T-handle with sliding square drive	240 3/4 N	1
Reversible ratchet with sealed mechanism	237 B 3/4	1

612 3/4" B
Code U06120016



BIHEXAGONAL SOCKETS

Assortment in sheet steel box with bihexagonal sockets

Ratchets and sockets

YouTube



Just **USAG**



16
PIECES

1/2"

1/4"



1 kg | mm | 190
58
144

601 1/4-1/2" JTX16

Code U06010009

Assortment with TORX® sockets in modular box

DESCRIPTION	SIZE	PCS.
TORX® sockets 1/4"	E6-E7-E8-E10	4
TORX® sockets 1/2"	E12-E14-E16-E18	4
TORX® socket bits 1/4"	T10-T15-T20-T25	4
TORX® socket bits 1/2"	T30-T40-T45-T50	4



34
PIECES

1/4"



1 kg | mm | 190
58
144

601 1/4" J34

Code U06010001

Assortment with hexagonal sockets and bits in modular box

DESCRIPTION	SIZE	PCS.
Hexagonal sockets 1/4"	4-4,5-5-5,5-6-7-8-9-10-11-12-13-14	13
Reversible ratchet 1/4"		1
Universal joint 1/4"		1
Extensions 1/4"	55-100	2
Bits for slot-head screws 1/4"	4-5,5-6	3
Bits for POZIDRIV® screws 1/4"	1-2-3	3
Bits for hexagonal screws 1/4"	4-5-6	3
TORX® bits 1/4"	T10-T15-T20-T25-T30-T40	6
Spinner with handle 1/4"		1
Bit-holder socket 1/4-1/4"		1



22
PIECES

1/2"



4 kg | mm | 375
80
186

601 1/2" J22

Code U06010003

Assortment with hexagonal sockets in modular box

DESCRIPTION	SIZE	PCS.
Hexagonal sockets 1/2"	8-10-11-12-13-14-15-16-17-18-19-21-22-24-27-30-32	17
Reversible ratchet 1/2"		1
Extensions 1/2"	130-250	2
Universal joint 1/2"		1
T-handle 1/2"		1

USAG QUALITY AT A *Just* PRICE



100
PIECES

1/4" **1/2"**

8 kg | mm | 415
92
283



601 1/4-1/2" J100

Code U06010011

Assortment with hexagonal sockets and bits in modular box



The boxes are modular with USAG roller cabinet drawers



82
PIECES

1/4" **1/2"**

7 kg | mm | 415
92
283



601 1/4-1/2" J82

Code U06010010

Assortment with hexagonal sockets and combination wrenches in modular box



16
PIECES

285 J/B16

Code U02851740

Set of 16 combination wrenches

• Delivered with roll-up bag



6-7-8-9-10-11-12-13-14
15-16-17-18-19-22-24 mm

GRIP BITS 458 E FOR DAMAGED HEXAGONAL SCREWS



YouTube



458 E/B9
Code U04580313

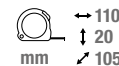

Set of grip bits for damaged hexagonal screws

- Special steel with phosphated finish
- Including 1/4-1/4" bit holding socket
- Supplied in a compact fabric pouch

DESCRIPTION	ITEM/SIZE	PCS.
Set of grip bits for damaged hexagonal screws	458 E 2-2,5-3-4-5-6-7-8	8
Bit-holding socket	684 1/4	1

2-2,5-3-4-5-
6-7-8 mm

1/4 Bit-holding
socket

ALSO EFFECTIVE ON EXTREMELY DAMAGED SCREWS



1/4" 1/4

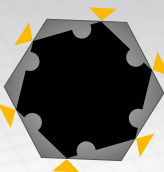

EXCLUSIVE PROFILE

The special design of the grip bits allows you to grip the hexagons recessed in any condition: intact or completely damaged.



DAMAGED SCREWS

When a screw with a hexagon socket-head is damaged, it is no more possible to unscrew it with normal hexagonal male keys. The new 458 E grip bits allow to unscrew even screws extremely damaged, up to 98% of the hexagonal profile.



458 S20
Code U04580312



Assortment of grip sockets and bits for damaged hexagonal screws and nuts

- 458 B: grip sockets with 3/8 or 1/2" connection and conical helicoidal profile
- 458 E: grip bits with 1/4" connection and exclusive special profile
- 1/4-1/4" bit holding socket included
- High resistance ABS case
- Inner foam module

DESCRIPTION	ITEM/SIZE	PCS.
Pullers for damaged nuts and screws	458 B 8-10-11-12-13-14-15-16-17-18-19	11
Set of grip bits for damaged hexagonal screws	458 E 2-2,5-3-4-5-6-7-8	8
Bit-holder sockets	684 1/4	1

COMPLETE KIT FOR DAMAGED SCREWS AND NUTS



1/4" 1/4

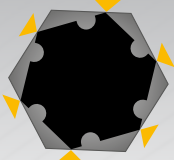

EXCLUSIVE PROFILE FOR HEXAGONAL SOCKET-HEAD SCREWS

The special design of the grip bits allows you to grip the hexagons recessed in any condition: intact or completely damaged.



3/8" 1/2"

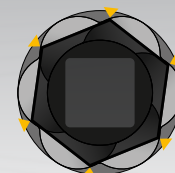

HELICOIDAL PROFILE FOR HEXAGONAL NUTS AND SCREWS

The conical helicoidal sockets guarantee an effective external grip on damaged hexagons.

454



Outside pullers with two jaws

- Model with sliding jaws
- Bar with tightening hexagon
- Jaws with small claws
- Carbon steel pressure screw
- Chrome Vanadium steel
- Chrome plated and burnished finish

CODE	A	B	POWER	Hex
U04540000	65 mm	70 mm	1,5 t	13 mm
U04540010	90 mm	110 mm	3 t	17 mm
U04540020	130 mm	110 mm	3 t	17 mm
U04540030	175 mm	165 mm	4 t	17 mm
U04540040	220 mm	165 mm	4 t	17 mm
U04540050	270 mm	220 mm	5 t	21 mm
U04540060	340 mm	220 mm	5 t	21 mm



4
PIECES

451 N/S4

Code U04510100

Outside puller with three jaws

- Model with self-locking jaws
- Safety pin
- Working screw with 18 mm hexagonal drive
- Possibility of using with two jaws
- Carbon steel pressure screw
- Chrome Vanadium steel body
- Chrome plated and burnished finish
- Working screw M16x2

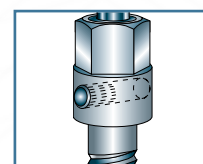

Safety pin increases working safety and preserves tool quality

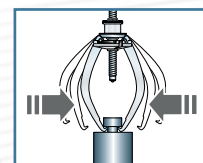

Self-locking
self-centring

EXTRACTORS FOR BROKEN AND STUD BOLTS

Ø 6÷14
mm

25
PIECES



460 A

Code U04600080

Set of extractors for stud bolts

- Supplied in plastic box

Ø 1÷6
mm

6
PIECES



458 S6

Code U04580012

Set of 6 conical extractors

- For removing broken stud bolts without surface to grip



TORQUE WRENCHES 810 SA - 811 SA WITH DIRECT READ SYSTEM.

REVERSIBLE RATCHET
with 72 theet mechanism.

CLICK TORQUE SYSTEM
with compression spring.

NEW

DIRECT READ
the value of the torque to apply is quickly visible.

QUICK TO ADJUST
you can set-up faster the torque needed.

CONICAL HANDLE
in anti-slip bimaterial.

810 SA

ISO 6789

NEW

Direct read torque wrench with reversible ratchet

- Calibration certificate and REACH (SVHC) declaration included

ITEM	CODE	CAPACITY	☑	L (mm)	RESOL.
810 SA 50	U08105002	10÷50	3/8"	350	0,25
810 SA 100	U08105003	20÷100	1/2"	410	0,5
810 SA 200	U08105005	40÷200	1/2"	475	1,0
810 SA 340	U08105006	60÷340	1/2"	630	1,0

CLOCKWISE TIGHTENING

PRECISION
±4%

3/8"

1/2"

Removable ratchet

NEW

811 SE

ISO 6789

Direct read torque wrench with removable ratchet

- Calibration certificate and REACH (SVHC) declaration included

ITEM	CODE	CAPACITY	☑	○	L (mm)	RESOL.
811 SE 50	U08115012	10÷50	3/8"	9x12	370	0,25
811 SE 100B	U08115013	20÷100	3/8"	9x12	430	0,5
811 SE 100C	U08115015	20÷100	1/2"	9x12	430	0,5
811 SE 200	U08115017	40÷200	1/2"	14x18	510	1,0
811 SE 340	U08115018	60÷340	1/2"	14x18	665	1,0

CLOCKWISE AND COUNTERCLOCKWISE TIGHTENING

PRECISION
±4%

3/8"

1/2"

810 N

ISO 6789

Torque wrenches with reversible ratchet

- Adjustable torque model for clockwise tightening
- Accuracy $\pm 4\%$ of the preset torque value
- Readings in Nm
- Sensible and audible alarm on reaching preset torque value
- Automatic resetting on pressure release after disengagement
- Supplied with test certificate

PRECISION
 $\pm 4\%$

1
4"

**CLOCKWISE
TIGHTENING**



ITEM	CODE	CAPACITY	☑	L (mm)	RESOL.
810 N 5	U08104000	1 ÷ 5	1/4"	197	0,05
810 N 25	U08104001	5 ÷ 25	1/4"	290	0,05

811 NE

ISO 6789

Torque wrenches with removable reversible ratchet

- Adjustable torque model for use in combination with fittings from the 811-series
- For clockwise and counterclockwise tightening by turning the fittings 180°
- 9x12 or 14x18 mm fittings
- Accuracy $\pm 4\%$ of the preset torque value
- Readings in Nm
- Sensible and audible alarm on reaching preset torque value
- Automatic resetting on pressure release after disengagement
- Supplied with test certificate
- Complete with reversible ratchet 811 E with 72 teeth

PRECISION
 $\pm 4\%$

1
4"

**CLOCKWISE AND
COUNTERCLOCKWISE
TIGHTENING**



ITEM	CODE	CAPACITY	☑	○	L (mm)	RESOL.
811 NE 5	U08114009	1 ÷ 5	1/4"	9x12	185	0,05
811 NE 25	U08114010	5 ÷ 25	1/4"	9x12	300	0,05

812 N

ISO 6789

Torque wrenches with reversible ratchet

- Adjustable torque model for clockwise and counterclockwise tightening by turning the ratchet 180°
- Accuracy $\pm 4\%$ of the preset torque value
- Readings in Nm
- Sensible and audible alarm on reaching preset torque value
- Automatic resetting on pressure release after disengagement
- Safety block after setting torque
- Supplied in sheet steel box with test certificate
- Ratchet with male square drive 3/4"

PRECISION
 $\pm 4\%$

3
4"

**CLOCKWISE AND
COUNTERCLOCKWISE
TIGHTENING**



ITEM	CODE	CAPACITY	☑	○
812 N 600	U08120006	120 ÷ 600	3/4"	14x18
812 N 1000	U08120010	200 ÷ 1000	3/4"	-

824 A

ISO 6789

Torque screwdrivers

- Adjustable torque model for clockwise tightening, for use in combination with bits from the 660 series or, using an adapter, with sockets from the 1/4" manual series
- Accuracy $\pm 6\%$ of the preset torque value
- Readings in Nm
- Automatic disengagement on reaching the preset torque value
- Automatic resetting after 120°
- Supplied with regulation key and test certificate

1/4"

PRECISION
 $\pm 6\%$

**CLOCKWISE
TIGHTENING**



CODE	CAPACITY	L (MM)	RESOL.
U08240004	0,5 ÷ 2,5	145	0,1
U08240006	2 ÷ 10	167	0,5

Controlled tightening

Controlled tightening using ratchets or T-wrenches

1/2"



YouTube

814 A

Torque-angle digital adapter

- Torque and angle tightening with digital precision using conventional tools
- For CW and CCW tightening
- Torque accuracy: $\pm 4\%$
- Angle accuracy: $\pm 2\%$
- Measuring mode: peak/track
- Measuring unit: Nm/ft.lb/in.lb/kgcm/degree
- Visible (LED) and audible (BUZZER) indicators when preset target value is reached
- 9 presettable target values
- 50 memory slots for measured values
- Supplied in ABS case with calibration certificate
- Power supply: 2 batteries AAA (included)

CODE	CAPACITY	RESOL.
U08140003	27 - 135	1/2" 0,1
U08140004	40 - 200	1/2" 0,1
U08140005	68 - 340	1/2" 0,1

Correct measurement of the angle in any position

PRECISION
 $\pm 2\%$



YouTube

831 A

Code U08310001

Digital angle meter

- Correct measurement of the angle in any position
- For CW and CCW tightening
- Accuracy: $\pm 2\%$
- Range: 0 - 360°
- Resolution: 0,1°
- Visible (LED) and audible (buzzer) indicators when preset target value is reached
- 9 presettable target values
- 50 memory slots for measured values
- Supplied in ABS case with calibration certificate
- Power supply: 2 batteries AAA (included)

Multiplication ratio

1:3,4

828 X4

Code U08280401

Torque multiplier

- Light compact model for use in maintenance of industrial vehicles, agricultural machinery and earth-moving equipment
- Supplied in nylon bag with safety lever and test certificate
- Transmission rate 4:1
- Max input torque: 400 Nm
- Multiplication ratio: 1:3,4
- Square female: 1/2"
- Square male: 3/4"



CAPACITY
1400
Nm

INPUT
1/2"

OUTPUT
3/4"

SCISSORS 207 E STEEL STRENGTH.



YouTube



**THE ONLY ONE WITH INTEGRAL
STAINLESS STEEL STRUCTURE**

Flexural strength 180 Kg.

**BUILT-IN WIRE
STRIPPER**



1. Stripping
2. Crimping

**CABLE CUTTER ON
BOTH BLADES**



Suitable for
multi-core cables.

**MICRO ANTI-SLIP
TOOTHING**



207 E

Code U02070006

Professional scissors for electricians



SCISSORS 207 D

THE REFERENCE FOR ELECTRICIANS.

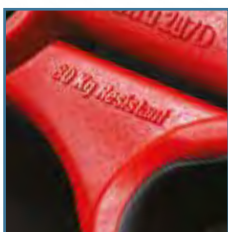

**HANDLES RESISTANT
TO FLEXURAL
STRENGTH UP TO 80 KG**
glass-reinforced technopolymer.

50 mm²

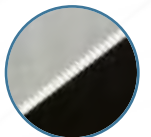

FLUID AND STRONG BLADES
with micro tothing and cable cutter.



**OVERSIZED
HOLES**

207 D

Code U02070008

Scissors for electricians,
stainless steel blades



YouTube



Ø 0,02÷10 mm²

146 B

Code U01460004

**Automatic wire strippers,
bent at 90°**



Ø 4÷28 mm²

163

Code U01630001

Multi-purpose cable sheath stripper

- For circular and longitudinal stripping of cables with external sheathing in PVC



YouTube



751

Code U07510002

**Crimping pliers for
pre-insulated terminals**



0,5÷1 mm²
1,5÷2,5 mm²
4÷6 mm²

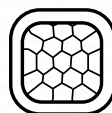

0,14÷10 mm²



753 KA

Code U07530004

**Self-adjusting crimping pliers
for square terminals**

Insulated



Non-Insulated



**9 DIFFERENT
SHAPES**

For cabinets and
technical fittings

767

Code U07670001

Universal cross-type wrench



- ⊖ 1-1,2-1,5-1,8-2-2,5-3 mm
- ⊕ PH0-PH00-PH000
- ⊕ T5-T6-T7-T8-T9
- ⊕ TT10-TT15-TT20
- ⊕ PZ0-PZ1
- 0,9-1,3-1,5-2-2,5-3-4 mm
- ⊕ PT2-PT3-PT4
- ⊖ PT0-PT1

341 SH33

Code U03410019

**Precision bit-holder screwdriver
with 32 bits**



**33
PIECES**

SMART FUNCTION

Automatically selects AC/DC
voltage, resistance,
frequency

MAX
600 V

RMS



074 A

Code U00740001

SMART digital multimeter

- AC/DC measurement
- Resistance and continuity measurements (acoustic sound if circuit resistance is lower than 40 to Ω)
- Frequency measurements
- AC/DC current measurement with 076 P ammeter

TECHNICAL CHARACTERISTICS

Direct voltage DC (mV=V)	1÷600 mV=V
Alternating voltage AC (mV=V)	1÷600 mV=V
Resistance (Ω =M Ω)	0÷10 Ω =M Ω
Frequency kHz	3÷40 kHz
Battery type (supplied)	2xAAA 1,5V



CAT III 600V

Ideal on the inverter
terminals of hybrid
and electric cars
(CEI 11-27)

MAX
690 V



076 G

Code U00760006

Voltage tester

- Tension/continuity test
- Phase/neutral identification
- Phase rotation test
- Visible and audible indication



TECHNICAL CHARACTERISTICS

Direct/Alternating voltage DC/AC (mV=V)	12÷690 mV=V
Frequency kHz	50÷60 kHz
Battery type (supplied)	1x9V



007 MV

Code U00070035

Tool-holding pouch (empty)

- High strength fabric
- Velcro belt fixing
- Four stretch pockets for tools
- Hook for tape



007 MLV

Code U00070030

Tool-holding pouch with belt (empty)

- High strength fabric
- Six stretch pockets for tools
- Hook for tape
- Adjustable belt from 80 to 120 cm

Rivet pliers

Ø
M4 - M5
M6 - M8



**DELIVERED IN
PLASTIC CASE**

995 CA
Code U09950008

Hand riveter for blind-nut rivets

- Compact model with internal lever system that reduces operator effort
- Supplied with 4 interchangeable nozzles (M4-M5-M6-M8)
- To be used with aluminium and steel blind nuts (M4-M5-M6-M8) and stainless steel (M4-M5)
- Light alloy body
- Plastic handles
- Supplied in a plastic case (LxDxH: 320x175x50 mm) with blind nuts holders (not included)



235 mm



**FOR BLIND-NUT
RIVETS**
(not included)

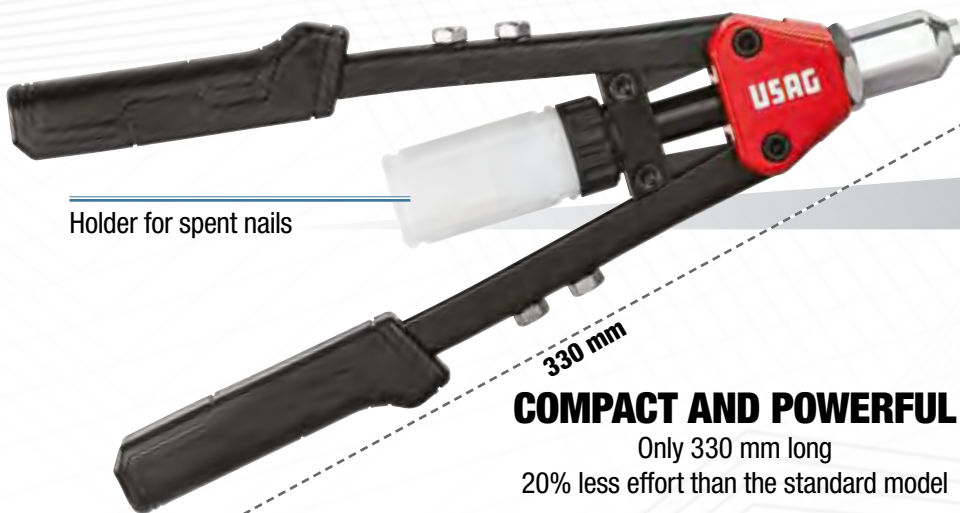

Holder for spent nails

330 mm

COMPACT AND POWERFUL

Only 330 mm long
20% less effort than the standard model

995 LA
Code U09950004

Straight compact hand riveter

- Compact model with the same capacity as a standard long riveter
- The internal lever system reduces operator effort
- Suitable for Aluminum and steel rivets
- 5 interchangeable nozzles
- Removable holder for spent nails
- Light alloy body
- Plastic handles



**-20%
EFFORT**

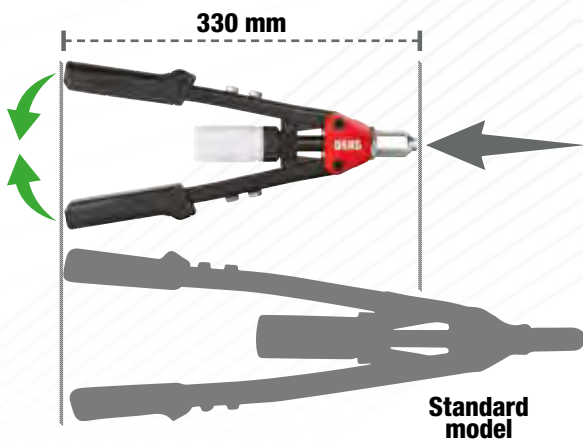

Standard model



ALUMINIUM AND STEEL

• Ø 2,4 mm
3/32"

• Ø 4,0 mm
5/32"

• Ø 6,4 mm
1/4"

• Ø 3,2 mm
1/8"

• Ø 4,8 mm
3/16"



995 A

Code U09950001

Hand riveter

- Light alloy body
- Pressed sheet steel pressure lever
- Handgrips with spring-action opening
- Supplied with three interchangeable nozzles and service key

ALUMINIUM AND STEEL

- Ø 2,4 mm 3/32"
- Ø 3,2 mm 1/8"
- Ø 4,0 mm 5/32"
- Ø 4,8 mm 3/16" **ALUMINIUM ONLY**



995 AF

Code U09950006

Hand riveter with swivel head

- 360° adjustable head
- Suitable for Aluminum rivets
- 4 interchangeable nozzles
- Light alloy body
- Plastic handles
- Metal clip for opening lock
- Supplied with head disassembly key

ALUMINIUM

- Ø 2,4 mm 3/32"
- Ø 3,2 mm 1/8"
- Ø 4,0 mm 5/32"
- Ø 4,8 mm 3/16"



SWIVEL HEAD



926 A

Code U09260001

Oleo-pneumatic riveter

- Supplied with four interchangeable nozzles and service key

ALUMINIUM AND STEEL

- Ø 2,4 mm 3/32"
- Ø 3,2 mm 1/8"
- Ø 4,0 mm 5/32"
- Ø 4,8 mm 3/16"



TECHNICAL CHARACTERISTICS

Stroke (mm)	14 mm
Average air consumption (l/min)	113 l/min
Recommended air pressure (bar)	6,2 bar
Vibrations (m/s ²)	1,3 m/s ²
Air inlet (")	1/4"
Ø hose size (mm)	10 mm



305 N

Swedish model pipe wrenches with straight jaws at 90°

- Chrome Vanadium steel

CODE	CAPACITY		LENGTH
U03050002	1"	40 mm	330 mm
U03050003	1 1/2"	55 mm	420 mm
U03050004	2"	67 mm	540 mm
U03050005	3"	103 mm	690 mm

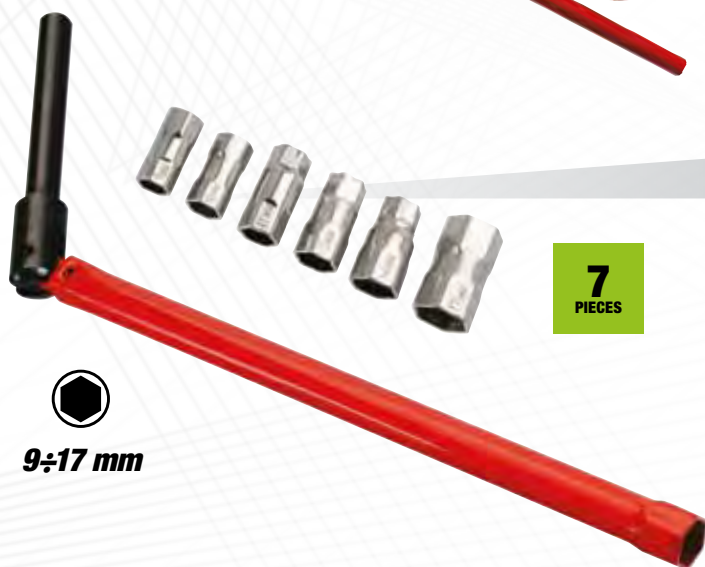

307 A/S7

Code U03070001

Basin wrench

- For washbasins and mixers with nut-fixing
- Hollow shaft, 25 cm length
- Hollow end for hexagonal nuts 13 mm
- Supplied with adapters: 9,10,11,12,14,17 mm

7
PIECES



9÷17 mm



317 K

Code U03170012

Tube cutters for plastic tubes

- For cutting PEX, PEHD, PVC, PER tubes
- Rack-type model for an effortless progressive cutting action
- Light alloy body
- Enamelled finish

PLASTICS

Ø
35
mm

Ø
1 3/8
"

Threaded steel insert for fast sliding



314 C

Code U03140032

Tube cutter for Copper and light alloy tubes

- Grooved guide-rollers for cutting flanged tubes
- Threaded steel insert for fast sliding
- Quick replacement of the wheel, without any tool
- Ergonomic knob
- Light alloy body
- Enamelled finish
- Maximum tube thickness: 2 mm

Ø
3-30
mm

Ø
1/8-1 1/8
"



COPPER

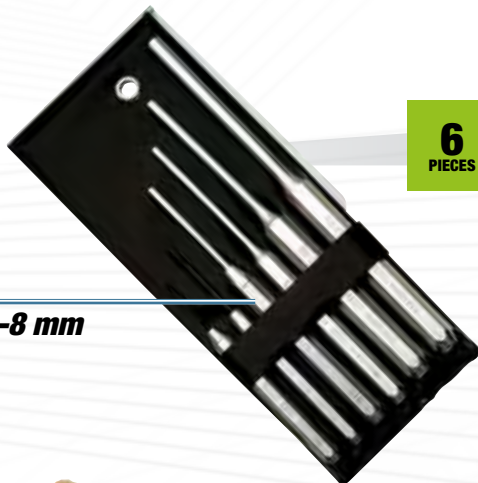

2-3-4-5-6-8 mm

6
PIECES

367 SE6

Code U03670081

Set of 6 pin punches

- 367/2x115-3x125-4x145-5x165-6x180-8x200 mm
- Supplied in plastic pouch
- Chrome Vanadium steel
- Inserted phosphatised tips for the 2 and 3 mm sizes



UNI 7784

376

Mallets

- Model with interchangeable plastic tips
- Carbon steel body
- Ash wood handle

CODE	TIP Ø	LENGTH
U03760001	22 mm	250 mm
U03760002	28 mm	275 mm
U03760003	35 mm	300 mm
U03760004	42 mm	325 mm
U03760005	50 mm	350 mm
U03760006	60 mm	380 mm



UNI 7777 DIN 6475

382

Hammers for mechanics

- German model with flat square head and symmetric peen
- Ash wood handle

CODE	HEAD	LENGTH
U03820002	100 g	260 mm
U03820004	200 g	280 mm
U03820006	300 g	300 mm
U03820007	400 g	310 mm
U03820008	500 g	320 mm
U03820009	600 g	330 mm
U03820010	800 g	350 mm
U03820011	1000 g	360 mm
U03820013	1500 g	380 mm
U03820014	2000 g	400 mm

Head in Carbon steel forged and subjected to differentiated heat treatment to guarantee a longer life and avoid chipping or upsetting of the striking surface.

DIN 338

HSS-G

14
PIECES



988 LA/S14
Code U09880070

Assortment with tap and drills

- Ø drills: 2,5-3,3-4,2-5,0-6,8-8,5-10,2
- M taps: 3x0,5-4x0,7-5x0,8-6x1-8x1,25-10x1,5-12x1,75

DIN 338

HSS-G

19
PIECES



988 MA/S19
Code U09880073

Assortment with drills

- Ø drills: 1,0-1,5-2,0-2,5-3,0-3,5-4,0-4,5-5,0-5,5-6,0-6,5-7,0-7,5-8,0-8,5-9,0-9,5-10,0

DIN 338

HSS-G

25
PIECES



988 MA/S25
Code U09880074

Assortment with drills

- Ø drills: 1,0-1,5-2,0-2,5-3,0-3,5-4,0-4,5-5,0-5,5-6,0-6,5-7,0-7,5-8,0-8,5-9,0-9,5-10,0-10,5-11,0-11,5-12,0-12,5-13,0



HSS

3
PIECES



988 D/S3
Code U09880020

Set of 3 stepped cutters

ITEM	Ø STEPS	Ø SHAFT	LENGTH
988 D1	4-5-6-7-8-9-10-11-12 mm	6 mm	65 mm
988 D2	4-6-8-10-12-14-16-18-20 mm	8 mm	75 mm
988 D3	4-6-8-10-12-14-16-18-20-22-24-26-28-30 mm	10 mm	100 mm

HSS

12
PIECES



988 G/S12
Code U09880100

Set of 10 bimetallic hole saws

- 10 pcs 988 G (Ø 19-22-25-29-35-38-44-51-57-64)
- Cutting depth Max 38 mm

HSS

10
PIECES

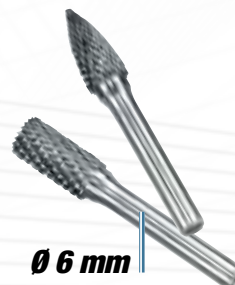

Ø 6 mm



988 E/S10
Code U09880062

Set of 10 rotary burrs in hard metal

- 8 pcs. (Ø 10 and 12 shapes EA-EC-EF-EG)
- 2 pcs (Ø 12 shapes ED-EM)

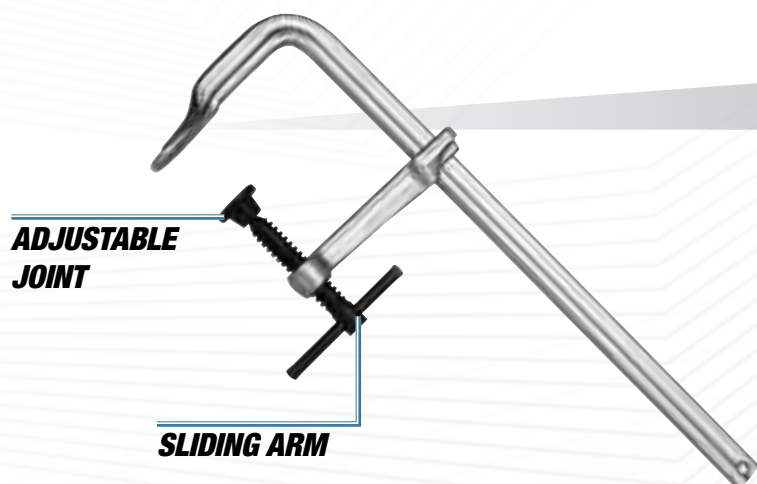

997 A

Screw-type clamp

- Body and sliding arm in forged steel

CODE	OPENING	SECTION	
U09970002	160 mm	16x7,5 mm	0,5 kg
U09970003	200 mm	19,5x9,5 mm	0,9 kg
U09970004	250 mm	22x10,5 mm	1,2 kg
U09970005	300 mm	25x12 mm	1,8 kg
U09970006	400 mm	25x12 mm	1,9 kg
U09970007	500 mm	25x12 mm	2,1 kg
U09970008	600 mm	25x12 mm	2,3 kg
U09970009	800 mm	27x13 mm	3,3 kg
U09970010	1000 mm	27x13 mm	3,7 kg

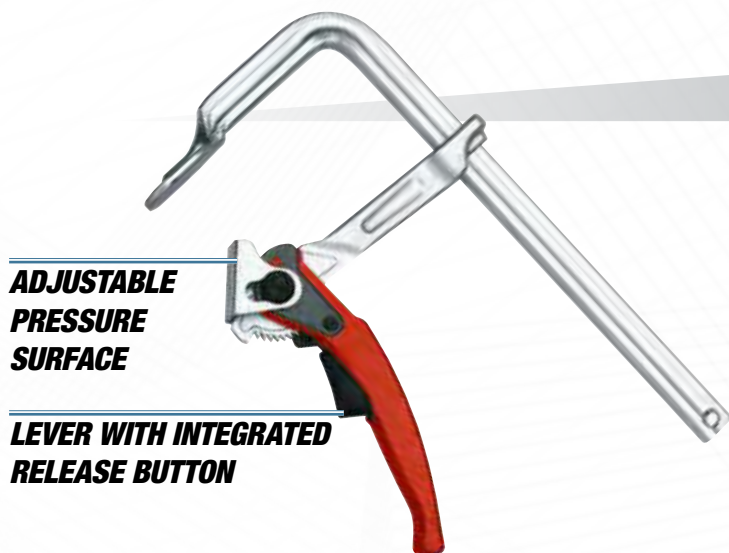

997 B

Lever-type clamp

- Quick lever model with precise regulation
- Body and sliding arm in forged steel
- Adjustable pressure cap

CODE	OPENING	SECTION	
U09970013	120 mm	13,5x6,5 mm	0,7 kg
U09970014	160 mm	16x7,5 mm	1 kg
U09970015	200 mm	19,5x9,5 mm	1,3 kg
U09970016	250 mm	22x10,5 mm	1,9 kg
U09970017	300 mm	25x12 mm	2,7 kg
U09970018	400 mm	25x12 mm	2,8 kg
U09970019	500 mm	25x12 mm	3 kg



200 S

Code U02000002

Hacksaw

- Steel body with anti-slip and shock resistant plastic coating
- Supplied with Cobalt blade 200 C24

BLADE TENSIONING SYSTEM
integrated into the handle

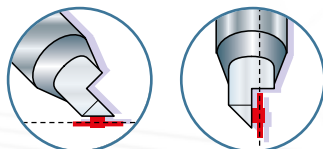

**RIGHT-HANDED
COARSE PITCH ISO
METRIC THREAD**

NEW

**40
PIECES**



618 MF1 Code U06180050

4,7 kg | mm | 425
83
395

Assortment with taps and tap wrenches in sheet steel case

Taps:

- Assortment with 3 taps, coarse pitch, metric thread for hard metal
- High-speed steel HSS
- Finish-ground thread
- Right-handed coarse pitch ISO metric thread
- Machining tolerances: 6H

Tap wrenches:

- Chrome Vanadium high-speed steel HSS with heat treatment 62/64 HRc (234 daN/mm²)
- Right-handed coarse pitch ISO metric thread
- Tapered screw that allows an easily adjustment based on threading diameters

DESCRIPTION	ITEM/SIZE	PCS.
Taps	M3 -M4 - M5 - M6 - M7 - M8 - M9 - M10 - M12	27
Dies	M3 -M4 - M5 - M6 - M7 - M8 - M9 - M10 - M12	9
Tap wrenches	618 M 1 - 2	2
Die stocks	832.1" - 832.1"1/2	2

**RIGHT-HANDED
COARSE PITCH ISO
METRIC THREAD**

NEW

**29
PIECES**



618 MF2 Code U06180051

2,6 kg | mm | 430
60
205

Assortment with taps in sheet steel case

- Assortment with 3 taps, coarse pitch, metric thread for hard metal
- High-speed steel HSS
- Finish-ground thread
- Right-handed coarse pitch ISO metric thread
- Machining tolerances: 6H

DESCRIPTION	ITEM/SIZE	PCS.
Taps	M3 -M4 - M5 - M6 - M7 - M8 - M9 - M10 - M12	27
Tap wrenches	618 M 1 - 2	2

NEW

**10
PIECES**



282 S10 Code U02820200

2 kg | mm | 330
215

Assortment in ABS case with pin wrenches for round and square ring nuts

- For rings with holes bored on the face
- The wrench is adjustable by turning the centre screw
- Removable pins
- Capacity: 20 to 100 mm
- Satin chrome finish
- High resistance ABS case with quick closing system
- Empty inner foam module: code U05191054Q

DESCRIPTION	SIZE	PCS.
Round pins	(d) 2,5 - 3 - 4 - 5 - 6 - 7 - 8 - 9 mm	4
Square pins	(a) 4 - 5 - 6 - 8 mm	4

FOR RINGS WITH CAPACITY DIAMETERS FROM 20 TO 100 MM

Rings with holes
on top

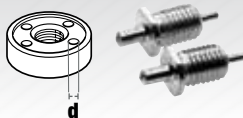

Rings with carvings
on top

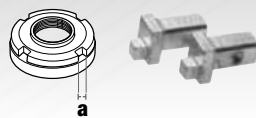



THE PRODUCTS OF USAG 493 RANGE ARE MANUFACTURED IN ITALY AND RESPECT THE HIGHEST SAFETY AND DURABILITY STANDARDS



EN 1492-1

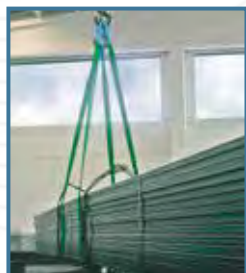

493 A

Two-ply webslings

- Safety coefficient 7:1
- Combination of colours and raising power according to the norms EN 1492-1

CODE	CHARGE	LENGTH
U04930002	1 t	2 m
U04930003	1 t	3 m
U04930004	1 t	4 m
U04930005	1 t	5 m
U04930006	1 t	6 m
U04930012	2 t	2 m
U04930013	2 t	3 m
U04930014	2 t	4 m
U04930015	2 t	5 m
U04930016	2 t	6 m
U04930022	3 t	2 m
U04930023	3 t	3 m
U04930024	3 t	4 m
U04930025	3 t	5 m
U04930026	3 t	6 m



EN 1492-1



493 B

Roundslings

- Structure with wear resistant sheath
- Safety coefficient 7:1
- Combination of colours and raising power according to the norms EN 1492-2

CODE	CHARGE	LENGTH
U04930052	1 t	1 m
U04930053	1 t	1,5 m
U04930054	1 t	2 m
U04930055	1 t	2,5 m
U04930056	1 t	3 m
U04930062	2 t	1 m
U04930063	2 t	1,5 m
U04930064	2 t	2 m
U04930065	2 t	2,5 m
U04930066	2 t	3 m
U04930072	3 t	1 m
U04930073	3 t	1,5 m
U04930074	3 t	2 m
U04930075	3 t	2,5 m
U04930076	3 t	3 m



EN 12195-2

493 C

Anchorage belt

- Belt width 35÷50 mm
- Ratchet-type tensioner 35÷50 mm
- Anchorage charge 1000÷2000 N
- Hook for codes U04930102, U04930103, U04930104
- Double hook for code U04930106
- Reference norm EN 12195-2

CODE	CHARGE	BELT
U04930102	1000 N	35 mm x 4 m
U04930103	1000 N	35 mm x 6 m
U04930104	2000 N	50 mm x 8 m
U04930106	2000 N	50 mm x 10 m

Lighting



SMD
LED



IP20



Lamp: 5 h
Torch: 9 h



4,5 h



IK07



Li-ion

889 RD

Code U08890035

LED inspection lamp



YouTube

DUAL USE



LAMP



TORCH

RECHARGEABLE



COB
LED



IP54



2,5/5 h



4 h



IK06



Li-Poly

889 SA

Code U08890019

LED extra-thin high-brightness inspection lamp



YouTube



RECHARGEABLE

USB



SMD
LED



2/5 h



Li-ion



IP54



6 h

889 TR

Code U08890073

Rechargeable LED torch in Aluminium - 600 Lumen

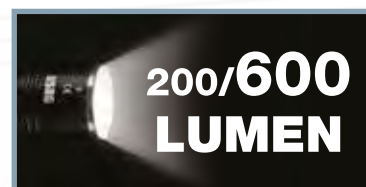

RECHARGEABLE

USB

360°



Lamp
COB LED

Torch
SMD LED

Lamp: 3h
Torch: 10h

IP20

4,5 h

Li-ion

889 RP

Code U08890045

Compact LED rechargeable inspection lamp



YouTube

DUAL USE



LAMP



TORCH

RECHARGEABLE USB



YouTube

180°



Magnetic base

COB LED

IP67

2,5 h

1 = 8 h
2 = 4 h
3 = 2,5 h

IK07

Li-ion

889 RT

Code U08890038

Rechargeable LED spotlight - certified IP67

3 BRIGHTNESS LEVELS



MAX
1500
LUMEN

500, 1000 and 1500 lumen with a simple touch

WORKS WITH OR WITHOUT CABLE

5 meters cable included



COB LED

IP54

24/6,5 h

3xAAA

889 LTE

Code U08890014

Frontal LED lamp



50/200
LUMEN



ADJUSTABLE



NON-SLIP STRAP



MOTION SENSOR

HYBRID AND ELECTRIC CAR MAINTENANCE



YouTube

THE MAIN OPERATIONS FOR THE CAR WORKSHOP:



SAFETY OF THE SYSTEM

Exclude the voltage of the electrical system in order to carry out vehicle maintenance.

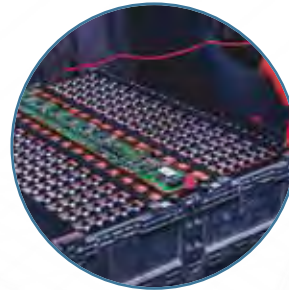

BATTERY CELL MAINTENANCE

Replace the single worn cells to recondition the battery pack.

DID YOU KNOW...

- A.** Hybrid and electric cars install electrical systems with **high and potentially dangerous voltages (over 200 V DC and 600 V AC)**.
- B.** Maintenance work on hybrid and electric cars is equivalent to electrical work, as specified by the regulations of each country.
- C.** To ensure safety during operations, equipment **with 1000V insulation must be used: tools, gloves, over-gloves and protective mat.**



INDIVIDUAL PROTECTION DEVICES

NEW



099 TG
Code U00990216

Pneumatic tester for insulated gloves

NEW



099 FS
Code U00990217

Face Shield

NEW



099 G
Code U00990218

Insulated gloves 1000 V

NEW



099 L
Code U00990219

Lockout padlock

NEW



099 H
Code U00990211

Insulated mats - 1000 V



099 BG
Code U00990221

Insulating rescue stick

USAG
FOR HYBRID
AND ELECTRIC



THE NECESSARY FOR SAFETY



8
PIECES

3
8"

↔ 435
↑ 70
mm ↗ 270

098 3/8" HYB8

Code U00980508



Assortment for safety of hybrid and electric cars in ABS case

- High resistance ABS case with quick closing system

DESCRIPTION	ITEM/SIZE	PCS.
Bihexagonal sockets - 1000 V	098 3/8" 8-10-12	3
Reversible ratchet 3/8" - 1000 V	098 A 3/8"	1
Extensions 3/8" - 1000 V	098 B 3/8" 150	1
Half-round extra-long nose pliers with straight jaws - 1000 V	081 EX 200	1
Screwdrivers for slot-head screws - 1000 V	091 1x5,5x125	1
Screwdrivers for PHILLIPS® screws - 1000 V	091 PH 2x125	1

ASSORTMENT FOR SAFETY AND MAINTENANCE OF BATTERY CELLS!



519 M 098HYB8

519 M 098HYB11

076 G

20
PIECES



495 098HYB

Code U04958010

Assortment for safety and maintenance of battery cells - 1 drawer

DESCRIPTION	ITEM	PCS.
1000 V bihexagonal sockets (8-10-12), 1000 V ratchet (098 A 3/8"), 1000 V extension 3/8", 1000 V screwdriver for slot-head screws (1x5,5x125), 1000 V screwdriver for PHILLIPS® screws (2x125), 1000 V half-round extra-large nose pliers	519 M 098HYB8	8
1000 V bihexagonal sockets (11-13-14), 1000 V bihexagonal ring wrenches (8-10-12-13-14), 1000 V screwdrivers for slot-head screws (0,5x3x75-0,8x4x100-1,2x6,5x150)	519 M 098HYB11	11
Voltage tester	076 G	1



5 DRAWERS
3 MODULES



20
PIECES



516 ST5HYA-S

Code U05168024

START roller cabinet with assortment for safety and maintenance of battery cells 495 098 HYB



DESCRIPTION	ITEM	PCS.
1000 V bihexagonal sockets (8-10-12), 1000 V ratchet (098 A 3/8"), 1000 V extension 3/8", 1000 V screwdriver for slot-head screws (1x5,5x125), 1000 V screwdriver for PHILLIPS® screws (2x125), 1000 V half-round extra-large nose pliers	519 M 098HYB8	8
1000 V bihexagonal sockets (11-13-14), 1000 V bihexagonal ring wrenches (8-10-12-13-14), 1000 V screwdrivers for slot-head screws (0,5x3x75-0,8x4x100-1,2x6,5x150)	519 M 098HYB11	11
Voltage tester	076 G	1





3500 A INTEGRATED TRANSFORMER

No external power supply.



12 V

1200 A

1613 RA12

Code U16130019

Professional start booster 12 V, portable

- For intensive professional use
- Straight clamps
- Shockproof ABS shell
- Also suitable for sealed batteries
- Supplied with charging cable (for optimal charging, it is recommended to connect the power plug to a direct power source; avoid multiple sockets)

AGM BATTERIES
(Absorbed Glass Mat)



3500 A

CABLE LENGTH

155 cm



TEST BUTTON

LED indication of battery charge status.



**SEAT FOR
CHARGING CABLE AND
CIGARETTE LIGHTER**

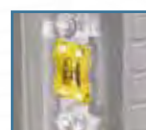

EXTERNAL FUSE
Overcurrent protection up to 300A. Easy to replace in case of overload.

REAR CONNECTOR FOR VOLTAGE SELECTION



12 V
24 V

1400 A
700 A

1613 AGM12-24

Code U16130013

Professional start booster 12-24 V, portable

- Shockproof ABS shell
- Overvoltage protection
- Also suitable for sealed batteries
- Inclined clamps
- Supplied with mains charger and cigarette lighter cable

AGM BATTERIES
(Absorbed Glass Mat)



12V - 3700 A

24V - 1860 A

CABLE LENGTH

155 cm



EXTERNAL FUSE

Overcurrent protection up to 300A.



VOLTMETER

to indicate the state of charge of the internal battery.

FOR 6÷12 V BATTERIES

Also for
Start & Stop



890 K

Code U08901000

Digital battery tester with printer

E-OBD OBD-II

ATTENTION
use this accessory
only with 12V boosters.



1613 OBD

Code U16130003

OBD memory saver 12 V

12 V

12 V



1612 BA12

Code U16120006

Central unit protector 12V

- Protects the control unit during welding operations or when starting with a charger, booster or cables

24 V



1612 BA24

Code U16120007

Central unit protector 24V

- Protects the control unit during welding operations or when starting with a charger, booster or cables

Measuring range: -60÷625°
Optical report: 16:1

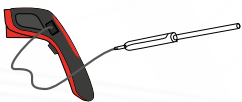

Compatible with
thermocouple K



YouTube



1651

Code U16510001

Digital infrared thermometer



22
PIECES



1881 S22

Code U18810082

Set of 22 wrenches for assembling and disassembling
the nuts of alternators pulleys

- Supplied in a plastic case

WHEEL LOCKING NUTS AND SCREWS REMOVER KIT



10
PIECES

272 DS
Code U02720001

Kit to extract nuts and screws from alloy wheels

- Does not damage the alloy rim
- Special tungsten carbide drills capable of drilling any type of material (lubricate with cutting oil at each use)
- Super thin conical sockets to center/extract on any type of alloy wheel

YouTube
TUTORIAL
VIDEO



EXTRACTOR DESIGNED TO RESIST 150 NM: IDEAL FOR BMW SCREWS.



Standard locking wheel nuts and screws:
unscrew quickly with the conical sockets



Nuts and screws with rotating ring:
drill and extract safely with the special tools.



YouTube

447 T
Code U04470101

Universal pneumatic shock absorber dismantler

- Ideal for cars
- Self-levelling system of the two upper arms: also fits into conical and disaligned springs
- Self-lubricating: no lubrication and/or greasing necessary on the sliding columns
- Supplied with lower brackets 447 TC1 (78÷130 mm) and 447 TC2 (105÷182 mm), vice 447 TA and universal upper clamps 447 TB1
- Compact dimensions for easy installation in the shop 470x450x1390 mm
- Complies with MACHINE DIRECTIVE 2006/42/CE

COMPRESSION POWER
735 kg (6 bar),
1226 kg (10 bar)

TECHNICAL CHARACTERISTICS

Compression power	735 kg (6 bar) - 1226 kg (10 bar)
Recommended air pressure (bar)	6÷10 bar
Piston stroke (mm)	420 mm
Cylinder	Aluminium alloy and nylon resin

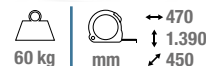

COMPLIANCE WITH MACHINE DIRECTIVE

USAG shock absorber dismantler is designed to comply completely with Directive 2006/42/EC. Some features of the machine have been set to ensure the maximum safety of the operator:

- Frontal protection
- Piston stop device in case of opening of the frontal protection
- Limited speed: always lower than 10 cm / sec
- Jaw and piston locking system in case of interruption of air supply.



3
PIECES

1 1/2"

270 C/C3
Code U02700106

Assortment with hexagonal impact sockets for tyre rims with teflon protection in modular box

→ 190
↑ 58
mm ↗ 144

17 19 21

1 1/2"

19,35 mm



Mercedes-Benz

80 mm



270 BM
Code U02700140

Impact socket wrench for Mercedes wheel nuts

- Suitable for models: C and GLK-Class (W204); E-Class (W211, W212, W207); SLK-Class (W172); ML-Class (W164, W166); CL-Class (W216); S-Class (W221, W222)



PROTECTIVE COATING

The special Teflon coating reduces the risk of damage when working on Aluminum alloy rims.



COLOR CODE

the Teflon coating makes each size easily recognizable.



ADJUSTABLE PRESSURE UP TO 4 BAR



Supplied with:

- spare gaskets
- 1 multi-diameter cap 44-45-46 mm (2847 N11)
- 1 tank for oil recovery.

2847/3
Code U28470084

12 V

Brake bleeder

- For changing, filling and bleeding the circuit of brakes on cars and industrial vehicles
- Device designed exclusively for brake fluids DOT 3, DOT 4, DOT 5.1. No LHM.
- Adjustable pressure up to 4 bar
- Automatic stop at 10% of the tank (1 L)
- Power supply 12 V with crocodile clips
- Rear accessory housing
- Integrated wheels and handle for easy transport

TECHNICAL CHARACTERISTICS

Operating liquid system	Paristaltic pump (no direct/liquid contact, no air pressure on liquid)
Power supply (V)	12 V (alligators clips)
Tank capacity (l)	10 liters
Pressure limiting device (bar)	4 bar
Elastic spiral hose (m)	4 m (elastic)
Power cable (m)	4 m

2847 N4
Code U28470098Q

Universal plug

- For brake bleeder 2847/2 and 2847/3



30,5 kg mm 615 344

3 TON **30,5** kg

CE

3t



2550 A

Code U25500001

Hydraulic service jack 3t for cars and commercial vehicles

- Steel structure
- Versatile and compact for use in narrow spaces
- High capacity for use on cars, SUVs and vans
- Dual pump system to lift the car faster
- Equipped with manual descent control
- Air bleed valve, to avoid risk of over-load
- Handle with rubber bumper
- Polyurethane wheels



615 mm

COMPACT
Only 615 mm length



133÷465 mm

32,5 kg mm 762 350

2 TON **32,5** kg

CE

2t

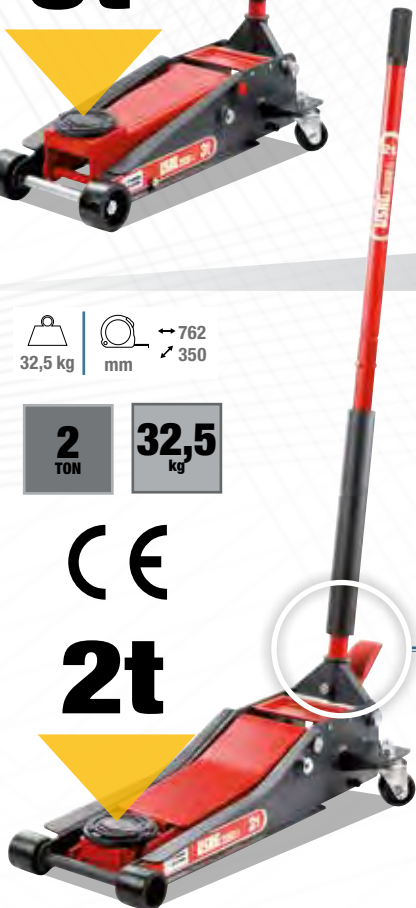

2550 B

Code U25500002

Hydraulic service jack 2t

- Steel structure
- Versatile and compact for use in narrow spaces
- Dual pump system to lift the car faster
- Equipped with lifting pedal
- Equipped with manual descent control
- Air bleed valve, to avoid risk of over-load
- Handle with rubber bumper
- Polyurethane wheels



THIN
only 75 mm height



75÷505 mm

Lifting pedal

1950 C

Pair of jack stands

- Adjustable height with toothed mechanism and lever release
- Locking pin with chain
- 1950 C/3: model adjustable in 10 positions
- 1950 C/6: model adjustable in 13 positions

2 PIECES



CODE	CAPACITY	H MAX	H MIN	DIMENSIONS	WEIGHT
U19501001	3 t	427 mm	300 mm	207x188 mm	7 kg
U19501002	6 t	620 mm	400 mm	285x250 mm	14 kg

TRUCK PRODUCT SELECTION



21
PIECES



2,6 kg | mm | 320
250
50



2800 S21
Code U28000085

Kit with 21 tools for brake pistons

- Compatible with the following car models: CITROEN, AUDI, FIAT / ALFA ROMEO, FORD, ISUZU, HONDA, JAGUAR, BMW, MERCEDES, MITSUBISHI, NISSAN, ROVER, TOYOTA, VOLVO, VOLKSWAGEN, MAZDA, SAAB, GM, SUBARU, PEUGEOT, RENAULT, MINI, OPEL

3/4"



Special Chrome
Molybdenum steel

235 3/4" MLS

Long impact hexagonal sockets with thin walls

- Ideal for dismantling TRUCK hubs like TRILEX, IVECO, MERCEDES, MAN, DAF, MAGIRUS, DEUTZ, RENAULT, SCANIA, ASTRA, VOLVO.

CODE	SIZE	Ø EXTERNAL	LENGTH
U02350272	27 mm	39 mm	100 mm
U02350273	30 mm	43 mm	100 mm
U02350274	32 mm	45 mm	100 mm
U02350275	33 mm	48 mm	100 mm



10
PIECES



YouTube

1,2 kg | mm | 360
65
160

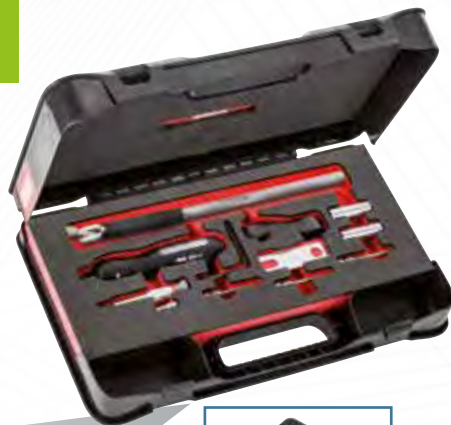

425 TPMS
Code U04250005

Kit with 10 tools to assemble / disassemble the tyre valves with Tyre Pressure Monitoring System (TPMS)



1,4÷10 Nm
Universal for all types of TPMS valves

CEE 86/217

SCALE BAR/PSI



927 MN
Code U09270003

Blow gun with gauge



22 mm

Ø MAX
23 mm



449 TA
Code U04490010

Ball-joint extractors for industrial vehicles

- For removing steering and suspension ball-joints
- Hexagonal drive 22 mm



22 mm

Ø MAX
25 mm



449 TB
Code U04490015

Ball-joint extractors for industrial vehicles

- For removing steering and suspension ball-joints
- Hexagonal drive 22 mm

3/4"

Ø MAX
42 mm



449 TC
Code U04490021

Ball-joint extractors for industrial vehicles

- For removing steering and suspension ball-joints
- Square drive 3/4"



YouTube

FAST OIL-FILTER WRENCH 443 N AUTOMATIC BELT CLAMPING.

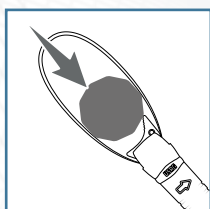

**AUTOMATIC
BELT CLAMPING**

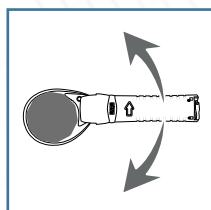

RATCHET EFFECT

Working rapidly. Possibility to work in narrow spaces.

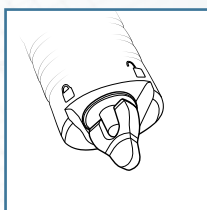

**LEVER TO INCREASE
CLAMPING POWER**



66÷105 mm



443 N

Code U04430005

Fast oil-filter wrench (cars)

106÷150 mm



443 NC

Code U04430007

Fast oil-filter wrench (industrial vehicles)

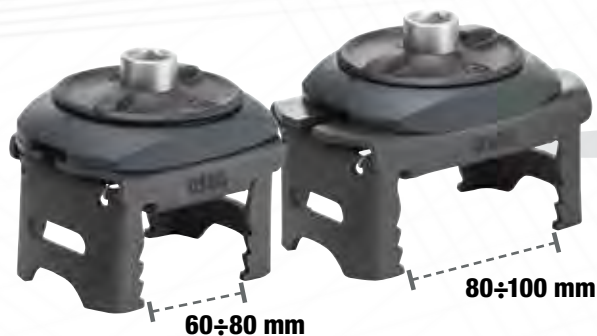

**2
PIECES**

3/8"



YouTube

446 E/SE2

Code U04460015

Set of 2 self-gripping oil filter wrenches

- 446 E/60÷80-80÷100 mm



446 DA/SE6

Code U04461104

Set of 6 cup wrenches for oil filters

- 3/8" square drive
- Steel body
- Set for Fiat, Lancia, Alfa Romeo, BMW, Renault, Volkswagen, Skoda, Audi, Seat, Mercedes
- Profile dimensions: Ø 74 mm x 14 sides - Ø 75 mm x 16 sides - Ø 86 mm x 16 sides - Ø 102 mm x 14 sides - Ø 66 mm x 18 sides - Ø 96 mm x 18 sides

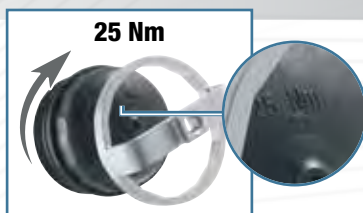

Allows the re-tightening at the original torque (value indicated on the plastic cap)

**6
PIECES**

3/8"



In aluminium

3/8"

27 mm

- Profile dimensions: Ø 64,5 mm x 14 sides
- Overall dimensions: (Øxh): 80x49 mm



2
PIECES

3/8"

27 mm

- Profile dimensions: Ø 64,5 mm x 14 sides
- Overall dimensions: (Øxh): 86x49 mm



446 DT/S2 Code U04461203

Set of two cap wrenches for oil filter covers - Japanese cars

- Can also be used to remove the Toyota oil filter cartridge
- Reduces the risk of damage to the oil filter covers
- Can also be used for tightening with a torque wrench
- Body in phosphatized Aluminium



Frame the QR code and download the list of applications or go to usag-tools.net



Specific for removing the oil filter covers on Toyota, Lexus, Daihatsu, Subaru engines



3/8"

1/2"

446 S28 Code U04461204

30
PIECES

Set of 30 oil-filter cap wrenches

- Set with 28 oil-filter cap wrenches with 3/8" square drive, 1 adapter 3/8"-1/2", 1 self-gripping wrench with 3/8" square drive (capacity 65÷120 mm)
- The set is suitable for the majority oil filters fitted on the following car brands: FIAT, ALFA, LANCIA, PEUGEOT, RENAULT, VOLKSWAGEN, AUDI, SEAT, SKODA, BMW, MERCEDES, VOLVO, SAAB, ROVER, JAGUAR, LOTUS, TOYOTA, SUZUKI
- Sizes of the oil-filter cap wrenches (Ø x N ° sides): 66/6 - 65/14 - 65/67 - 68/14 - 73/14 - 74/15 - 74/76 - 75/77 - 76/12 - 76/14 - 76/30 - 76/8 - 78/15 - 80/15 - 80/82 - 86/16 - 86/18 - 90/15 - 92/10 - 93/15 - 93/36 - 93/45 - 95/15 - 96/18 - 100/15 - 106/15 - 108/15 - 108/18
- Carbon steel body, burnished finish
- Supplied in plastic case with carrying handle and closing clip



7 kg | 620 mm | 70 mm | 500

Connection for oil collector

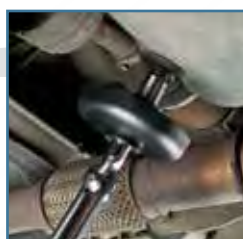

INTEGRATED OIL COLLECTION TRAY

263/S16 Code U02631400

16
PIECES

Oil draining kit

- Magnetic sockets to hold plugs.
- 1 hinged wrench 3/8".
- 2 bits Ø 8-10 mm.
- 6 bits Ø 8-10-12-13-14-17 mm.
- 6 hexagonal sockets 13-14-17-18-19-21 mm.
- 1 TORX® bit T45.

3/8"



LED temperature indicator



391

Code U03910001

Digital heat gun

- Model with electronic checking of temperature and air volume by digital display
- Possibility to set programs: 2 heating modes and 2 air flows selectable
- Equipped with a cooling system
- Supplied with one wide slit nozzle and one deflector nozzle

2 MODES:

- 1 250 l/min - 50°÷400°C
- 2 500 l/min - 50°÷600°C

MAX
600°

2000
WATT



**ACCESSORIES
INCLUDED**

NEW

5
PIECES



324 LTX/SH5

Code U03240500

Set of 5 long blade screwdrivers for TORX® screws

- 324 LTX T20x275 - T25x275 - T27x275 - T30x275 - T40x275



NEW

2
PIECES

340 mm



115 CL/SE2

Code U01150022

Double-joint pliers with straight half-round jaws

- Ideal for gripping pieces and parts difficult to reach
- Pointed jaws with knurled gripping surface
- Up to 70% longer than normal long nose pliers
- Small size double joint for maximum accessibility
- Handles covered in anti-slip material

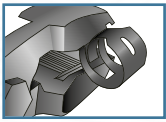

2 in 1

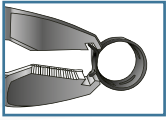

871 D

Code U08710001



Pliers for CORBIN clamps

- Model with frontal or side hooking
- Jaws with serrated gripping surface
- Inside spring
- Ergonomic anti-slip handles



870 C

Code U08700006

Pliers for fuel hoses

- For petrol and diesel vehicles
- Ergonomic bimaterial handgrip

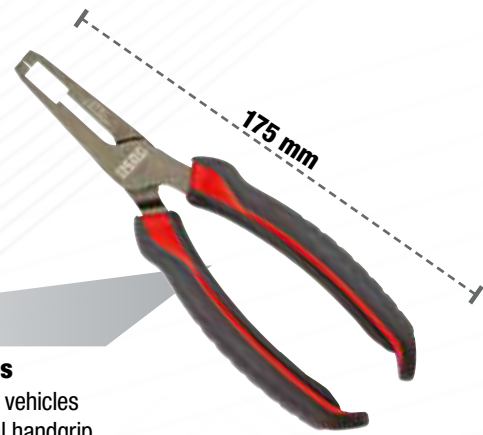

3 working positions



871 C

Code U08719005P

CLICK spring-clips pliers

- Three-axial heads to work in any position
- To open and close CLICK spring-clips on fuel circuits, intake manifolds and hydraulic circuits
- Steel body, phosphatized finish
- Ergonomic bimaterial handgrip



468 M

Bearings and seals drivers

- It simplifies the insertion of external rings for angular ball bearings
- Axis, bearing seat and sealing rings are not damaged
- Adjustable ring in 3 positions
- Steel handle
- It can be used on most vehicles, including motorcycles



CODE	CAPACITY	LENGTH
U04680150	9,5÷50 mm	176 mm
U04680151	18÷90 mm	210 mm

9
PIECES

Two wire brushes
Ø 20mm and 25mm

885 F

Code U08850004

Injector cleaning kit

- Ideal for duct cleaning of injectors mounted on common rail engines



6
PIECES

1/2"

884 C/S6

Code U08841000

Set of six wrenches for injector pipes fittings

- For assembly and disassembly of injectors pipes fittings
- Length: 98 mm
- Sizes: 12-14-16-17-18-19 mm



12
PIECES

**UNIVERSAL FOR
AIRBAG**



426 SAB
Code U04260010

Airbag service kit

- Suitable for the following car models: VW Bora, Golf 4, Jetta, Lupo, New Beetle, Passat B5, Polo; Audi A4, A6; BMW; Mercedes-Benz; Opel; Renault; Seat; Skoda Fabia, Octavia, Superb

4
PIECES

To separate timing belt cover, cylinder head engine, drive belt etc.



426 D/S4
Code U04260005

Set of 4 plastic separator scrapers

4
PIECES

For removal of counterweights, silicone, mouldings etc.



426 C/S4
Code U04260007

Set of 4 multi-purpose plastic scrapers

5
PIECES

To extract mouldings, fasteners, trim clips from door panels and dashboards



426 B/S5
Code U04260006

Set of 5 tools for plastic elements

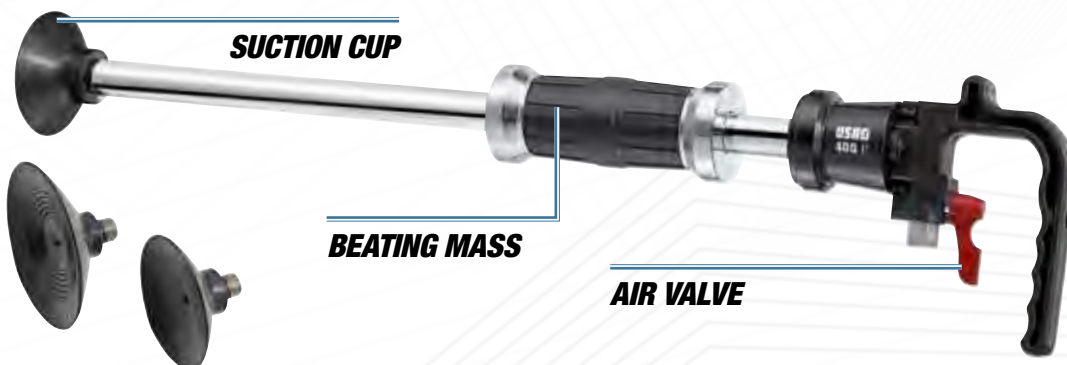

TECHNICAL CHARACTERISTICS

Suction cup threaded connection	M18
Sound level (dB)	78 Db
Total length	610 mm
Weight	4 Kg
Recommended air pressure (bar)	6,2 bar
Air inlet (")	1/4"

400 P
Code U04000010

Pneumatic dent puller

- Ideal to remove dents without the need to repaint
- Supplied with 3 suction cups (Ø 75-100-125 mm), in a plastic case with transport handle and closure clip
- Spare part kit with 3 suction cups: code 1004735-98



9,5

Liters



4,1 kg | 230 mm | 627 | 302



1785 B

Code U17850005

Fluid extractor

TECHNICAL CHARACTERISTICS

Recommended air pressure (bar)	5÷8 bar
Temperature aspirated liquids range (°C)	1÷100 °C
Tank capacity (l)	9,5 liters
Accessories contained	1 main hose 1500 x 16 mm - 4 suction hoses: 400 x 9,5 mm, 700 x 6 mm, 850 x 7,700 x 6



4,6 kg | 1.030 mm | 480 | 115



150 kg

2000 A

Code U20000100

Inspection creeper

- Headrest in vinyl resistant to hydrocarbons, padded with high resistance foam rubber
- Plastic body resistant to hydrocarbons, washable
- Two side trays for tools
- Maximum height from ground 115 mm
- Supplied with 6 swivelling rubber wheels Ø 80 mm (not assembled)

250 seat covers



3781 E

Code U38000075

Seat Covers

- Polyethylene
- Double format, covers completely the seat, including the rear part
- Thickness: 13 micron
- Dimensions: 70x165 cm
- Coil of 250 pieces

250 paper floor mats

1 steering wheel cover coil

250 seat covers



3781 A

Code U38000072

Workshop set service

- Delivered with display stand

3781 C

Code U38000073

Paper floor mats

- Moquette-cover in blotting paper
- Dimensions: 45x35 cm
- Pack with 250 pieces



3781 D

Code U38000074

Steering wheel cover

- To protect steering wheel in workshops
- Stretchable film
- Complete with unroll device in plastics
- Pack with 5 coils



LED LIGHTING

1/2"

1.898 Nm
2,2 kg



YouTube

MAGNESIUM ALLOY CASING



THE TOP OF THE RANGE

943 PC1 1/2"

Code U09430001

Magnesium impact wrench with LED - the top

TECHNICAL CHARACTERISTICS	TECHNICAL CHARACTERISTICS
Square drive (")	1/2"
Bolt capacity	M20
Max torque (Nm)	1.898 Nm
Torque in use (Nm min-Max)	320÷460 Nm
Strokes per minute	1200
Free speed (rpm)	6.500 rpm
Average air consumption (l/min)	172 l/min
Recommended air pressure (bar)	6,2 bar
Sound level dB(A)	94 ±3 dB(A)
Sound power dB(A)	105 ±3 dB(A)
Vibrations (m/s ²)	6,4 m/s ²
Air inlet (")	1/4"
Ø internal hose (mm)	10 mm
Weight	2,2 kg

MAGNESIUM ALLOY CASING

1/2"

1.600 Nm
2 kg



YouTube



THE REFERENCE MODEL

929 PC1 1/2"

Code U09290001

Magnesium impact wrench

TECHNICAL CHARACTERISTICS	TECHNICAL CHARACTERISTICS
Square drive (")	1/2"
Bolt capacity	M16
Max torque (Nm)	1.600 Nm
Torque in use (Nm min-Max)	280÷440 Nm
Strokes per minute	1.300
Free speed (rpm)	7.000 rpm
Average air consumption (l/min)	172 l/min
Recommended air pressure (bar)	6,2 bar
Sound level dB(A)	93 ±3 dB(A)
Sound power dB(A)	104 ±3 dB(A)
Vibrations (m/s ²)	6,2 m/s ²
Air inlet (")	1/4"
Ø internal hose (mm)	10 mm
Weight	2,0 kg

EXTRA-COMPACT



942 PC3 1/2"

Code U09420012

Extra-compact impact wrench

TECHNICAL CHARACTERISTICS	TECHNICAL CHARACTERISTICS
Square drive (")	1/2"
Bolt capacity	M16
Max torque (Nm)	861 Nm
Torque range (Nm)	150÷220 Nm
Strokes per minute	1650
Free speed (rpm)	10.000 rpm
Average air consumption (l/min)	127 l/min
Recommended air pressure (bar)	6,2 bar
Sound level dB(A)	91,1±3 dB(A)
Sound power dB(A)	108,1±3 dB(A)
Vibrations (m/s ²)	9,57 m/s ²
Air inlet (")	1/4"
Ø hose size (mm)	10 mm
Weight	1,3 kg



YouTube

YouTube



Modular with the drawers of USAG roller cabinets

943 PC1/C12

Code U09430005



1 1/2"

Assortment with hexagonal sockets and impact wrench in modular box

12
PIECES

DESCRIPTION	ITEM/SIZE	PCS.
Magnesium impact wrench with LED - the top	943 PC1 1/2	1
Impact hexagonal sockets	235 1/2 M/ 10-13-17-18-19-22-24-27-30-32 mm	10
Lock pins	235 MCA/4-6	2
Safety rings	235 MDA/4-6	2
Impact extensions	236 1/2 M/125	1



Modular with the drawers of USAG roller cabinets

929 PC1/C12

Code U09290005

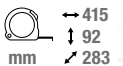

1 1/2"

Assortment with hexagonal sockets and impact wrench in modular box

12
PIECES

DESCRIPTION	ITEM/SIZE	PCS.
Magnesium impact wrench	929 PC1 1/2	1
Impact hexagonal sockets	235 1/2 M/ 10-13-17-18-19-22-24-27-30-32 mm	10
Lock pins	235 MCA/4-6	2
Safety rings	235 MDA/4-6	2
Impact extensions	236 1/2 M/125	1



Modular with the drawers of USAG roller cabinets

942 PC3/C7

Code U09420015

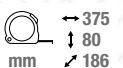

1 1/2"

Assortment with hexagonal sockets and impact wrench in modular box

7
PIECES

DESCRIPTION	ITEM/SIZE	PCS.
Extra-compact impact wrench	942 PC3 1/2	1
Impact hexagonal sockets	235 1/2 M/ 13-17-19-21-22-24 mm	6
Lock pins	235 MCA/4	1
Safety rings	235 MDA/4	1



LED LIGHTING

MAGNESIUM ALLOY CASING

ALUMINIUM BODY

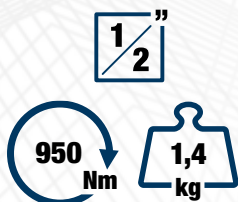

943 PC2 1/2"

Code U09430002

Magnesium impact wrench with LED - extra compact

TECHNICAL CHARACTERISTICS	
Square drive (")	1/2"
Bolt capacity	M16
Max torque (Nm)	950 Nm
Torque in use (Nm min-Max)	200÷270 Nm
Strokes per minute	1400
Free speed (rpm)	10.000 rpm
Average air consumption (l/min)	167 l/min

TECHNICAL CHARACTERISTICS	
Recommended air pressure (bar)	6,2 bar
Sound level dB(A)	95±3 dB(A)
Sound power dB(A)	107±3 dB(A)
Vibrations (m/s ²)	3,9 m/s ²
Air inlet (")	1/4"
Ø internal hose (mm)	10 mm
Weight	1,4 kg

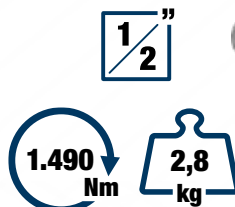

928 AC1 1/2"

Code U09280014

Aluminium impact wrench

TECHNICAL CHARACTERISTICS	
Square drive (")	1/2"
Bolt capacity	M16
Max torque (Nm)	1.490 Nm
Torque in use (Nm min-Max)	135÷380 Nm
Strokes per minute	1.120
Free speed (rpm)	6.500 rpm
Average air consumption (l/min)	147 l/min
Recommended air pressure (bar)	6,2 bar

TECHNICAL CHARACTERISTICS	
Sound level dB(A)	90 ±3 dB(A)
Sound power dB(A)	101 ±3 dB(A)
Vibrations (m/s ²)	5,2 m/s ²
Air inlet (")	1/4"
Ø internal hose (mm)	10 mm
Weight	2,8 kg



FLAT AND COMPACT HEAD
ideal for use in confined spaces.



913 PB2 3/8"

Code U09130011

Compact impact ratchet

TECHNICAL CHARACTERISTICS	
Square drive (")	3/8"
Bolt capacity	M10
Max torque (Nm)	54 Nm
Free speed (rpm)	300 rpm
Average air consumption (l/min)	110 l/min
Recommended air pressure (bar)	6,2 bar

TECHNICAL CHARACTERISTICS	
Sound level dB(A)	92±3 dB(A)
Sound power dB(A)	103±3 dB(A)
Vibrations (m/s ²)	3,9 m/s ²
Air inlet (")	1/4"
Ø hose size (mm)	6 mm
Weight	0,5 kg

913 PC2 1/2"

Code U09130017

Impact ratchet

TECHNICAL CHARACTERISTICS	
Square drive (")	1/2"
Bolt capacity	M10
Max torque (Nm)	136 Nm
Free speed (rpm)	280 rpm
Average air consumption (l/min)	113 l/min
Recommended air pressure (bar)	6,2 bar

TECHNICAL CHARACTERISTICS	
Sound level dB(A)	99±3 dB(A)
Sound power dB(A)	110±3 dB(A)
Vibrations (m/s ²)	9,1 m/s ²
Air inlet (")	1/4"
Ø hose size (mm)	10 mm
Weight	1,2 kg

TITANIUM ALLOY CASING



3/4"

2.115 Nm
3,8 kg

942 PD1 3/4"
Code U09420004

Impact wrench (Titanium structure)

TECHNICAL CHARACTERISTICS	
Square drive (")	3/4"
Bolt capacity	M27
Max torque (Nm)	2.115 Nm
Torque in use (Nm min-Max)	500÷800 Nm
Strokes per minute	950
Free speed (rpm)	5.300 rpm
Average air consumption (l/min)	200 l/min

TECHNICAL CHARACTERISTICS	
Recommended air pressure (bar)	6,2 bar
Sound level dB(A)	97,8±3 dB(A)
Sound power dB(A)	108,8±3 dB(A)
Vibrations (m/s ²)	5,06 m/s ²
Air inlet (")	3/8"
Ø hose size (mm)	10 mm
Weight	3,8 kg



3/4"

1.700 Nm
5,6 kg

928 D1 3/4"
Code U09280015

Aluminium impact wrench

TECHNICAL CHARACTERISTICS	
Square drive (")	3/4"
Bolt capacity	M24
Max torque (Nm)	1.700 Nm
Torque in use (Nm min-Max)	500÷1.050 Nm
Strokes per minute	790
Free speed (rpm)	5.700 rpm
Average air consumption (l/min)	193 l/min

TECHNICAL CHARACTERISTICS	
Recommended air pressure (bar)	6,2 bar
Sound level dB(A)	98,4±3 dB(A)
Sound power dB(A)	109,4±3 dB(A)
Vibrations (m/s ²)	9,1 m/s ²
Air inlet (")	3/8"
Ø hose size (mm)	13 mm
Weight	5,6 kg



1"

3.390 Nm
6,8 kg

942 PE1 1"
Code U09420005

Impact wrench (composite material frame)

TECHNICAL CHARACTERISTICS	
Square drive (")	1"
Bolt capacity	M38
Max torque (Nm)	3.390 Nm
Torque in use (Nm min-Max)	203÷1.627 Nm
Strokes per minute	900
Free speed (rpm)	5.000 rpm
Average air consumption (l/min)	400 l/min

TECHNICAL CHARACTERISTICS	
Recommended air pressure (bar)	6,2 bar
Sound level dB(A)	100,9 ±3 dB(A)
Sound power dB(A)	111,9 ±3 dB(A)
Vibrations (m/s ²)	10,6 m/s ²
Air inlet (")	1/2"
Ø hose size (mm)	19 mm
Weight	6,8 kg

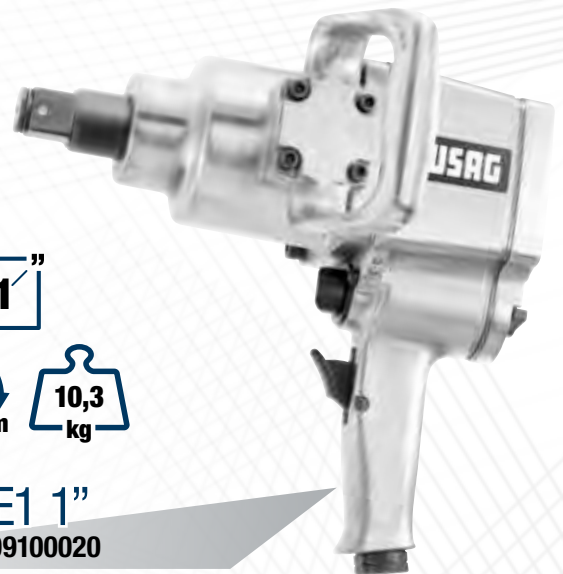

1"

4.068 Nm
10,3 kg

910 E1 1"
Code U09100020

Aluminium impact wrench

TECHNICAL CHARACTERISTICS	
Square drive (")	1"
Capacity (Nm)	M33
Max torque (Nm)	4.068 Nm
Torque in use (Nm min-Max)	850÷1.300 Nm
Strokes per minute	720
Free speed (rpm)	4.500 rpm
Average air consumption (l/min)	243 l/min

TECHNICAL CHARACTERISTICS	
Recommended air pressure (bar)	6,2 bar
Sound level dB(A)	102 ±3 dB(A)
Sound power dB(A)	113 ±3 dB(A)
Vibrations (m/s ²)	15,2 m/s ²
Air inlet (")	1/2"
Ø hose size (mm)	13 mm
Weight	10,3 kg

152
mm

5
mm

105
l/min

COMPACT
221 mm



920 AN1
Code U09200011

Roto-orbital sander (orbit 5 mm)

TECHNICAL CHARACTERISTICS

Power (Kw)	0,19 Kw
Ø Pad capacity	Ø 152 mm
Orbit (mm)	5 mm
Free speed	10.000 rpm
Average air consumption (l/min)	105 l/min
Recommended air pressure (bar)	6,2 bar
Sound level dB(A)	78,9±3 dB(A)
Sound power dB(A)	79,9±3 dB(A)
Vibrations (m/s ²)	11,8 m/s ²
Air inlet (")	1/4"
Ø hose size (mm)	10 mm
Weight	0,8 kg



125
mm

750 W

12.000
Rpm



921 A4
Code U09210012

Angle grinders

TECHNICAL CHARACTERISTICS

Disk diameter	Ø 125 mm
Ø disk connection	Ø 24 mm
Power	0,75 Kw
Free speed	12.000 rpm
Average air consumption	120 l/min
Recommended air pressure	6,2 bar
Sound level	86±3 dB(A)
Sound power	94±3 dB(A)
Vibrations	2,5 m/s ²
Air inlet	1/4"
Weight	1,9 Kg



16 M CABLE
10 MM

939 C1
Code U09390004

**Air hose reel
10 mm**

TECHNICAL CHARACTERISTICS

Hose length (m)	16 m
Ø internal hose (mm)	10 mm
Max pressure (bar)	15 bar
Output threaded male connector	3/8"
Dimensions (bracket included)	450x400x230 mm
Weight	8 kg



20.000 Rpm

0,4 CV
300 W

Ø 6
mm

113
l/min

142 mm

921 B1
Code U09210015

Straight die grinder - 0,4 CV (300W)

TECHNICAL CHARACTERISTICS

Average air consumption (l/min)	113 l/min
Recommended air pressure (bar)	6,2 bar
Sound level dB(A)	93,3±3 dB(A)
Sound power dB(A)	104,3±3 dB(A)

TECHNICAL CHARACTERISTICS

Vibrations (m/s ²)	2,5 m/s ²
Air inlet (")	1/4"
Ø hose size (mm)	10 mm
Weight	660 g



30.000 Rpm

0,3 CV
220 W

Ø 6
mm

76
l/min



922 B1

Code U09220001

Straight grinder - 0.3 CV (220 W)

TECHNICAL CHARACTERISTICS

Average air consumption (l/min)	76 l/min
Recommended air pressure (bar)	6,2 bar
Sound level dB(A)	84,8±3 dB(A)
Sound power dB(A)	99,5±3 dB(A)

TECHNICAL CHARACTERISTICS

Vibrations (m/s ²)	2,42 m/s ²
Air inlet (")	1/4"
Ø hose size (mm)	10 mm
Weight	440 g

25.000 Rpm

0,5 CV
368 W

Ø 6
mm

113
l/min



922 B2

Code U09220002

Straight grinder - 0.5 CV (368 W)

TECHNICAL CHARACTERISTICS

Average air consumption (l/min)	113 l/min
Recommended air pressure (bar)	6,2 bar
Sound level dB(A)	85,4±3 dB(A)
Sound power dB(A)	99,8±3 dB(A)

TECHNICAL CHARACTERISTICS

Vibrations (m/s ²)	1,86 m/s ²
Air inlet (")	1/4"
Ø hose size (mm)	10 mm
Weight	675 g

23.000 Rpm

0,3 CV
220 W

Ø 6
mm

76
l/min



922 BP1

Code U09220004

90° Angle grinder - 0.3 CV (220 W)

TECHNICAL CHARACTERISTICS

Average air consumption (l/min)	76 l/min
Recommended air pressure (bar)	6,2 bar
Sound level dB(A)	85,9±3 dB(A)
Sound power dB(A)	96,9±3 dB(A)

TECHNICAL CHARACTERISTICS

Vibrations (m/s ²)	4,54 m/s ²
Air inlet (")	1/4"
Ø hose size (mm)	10 mm
Weight	555 g

28.000 Rpm

0,3 CV
220 W

Ø 6
mm

76
l/min



922 BL1

Code U09220003

Long anvil straight grinder - 0.3 CV (220 W)

TECHNICAL CHARACTERISTICS

Average air consumption (l/min)	76 l/min
Recommended air pressure (bar)	6,2 bar
Sound level dB(A)	83,3±3 dB(A)
Sound power dB(A)	94,3±3 dB(A)

TECHNICAL CHARACTERISTICS

Vibrations (m/s ²)	2,86 m/s ²
Air inlet (")	1/4"
Ø hose size (mm)	10 mm
Weight	664 g



6
PIECES

1 1/2"

↔ 210
↓ 60
↗ 130
mm

233 1/2" MNTX/C6

Code U02332514



Assortment with long **IMPACT** socket bits for **TORX®** screws in **ABS** case

DESCRIPTION	ITEM/SIZE	PCS.
Long impact socket bits for TORX® screws	233 1/2 MNTX T30-T40-T45-T50-T55-T60	6



16
PIECES

1 1/2"

↔ 210
↓ 60
↗ 130
mm

687 1/2" C16

Code U06870100



Assortment with **IMPACT** bits in **ABS** case

DESCRIPTION	ITEM/SIZE	PCS.
Impact bit-holder sockets	685 6 1/2	1
Impact bit-holder sockets	685 8 5/16	1
Impact bits for hexagonal screws - 1/2" connection	687 E 6-7-8-10-12-14	6
Impact bits for TORX® screws - 1/2" connection	687 TX T30-T40-T45-T50-T55	5
Impact bits for PHILLIPS® screws - 5/16" connection	686 PH 2-3-4	3



6
PIECES

3 3/4"

↔ 210
↓ 60
↗ 130
mm

688 3/4" MD6

Code U06880010



Assortment with **IMPACT** bits in **ABS** case

DESCRIPTION	ITEM/SIZE	PCS.
Holder for impact bits	685 B 1 7/8	1
Impact bits for hexagonal screws - 7/8" connection	688 E 12-17-19-22-24	5



Range of bit-holders 685 B and **IMPACT** bits 688

ANTI-CORROSION AND ANTI-WEAR

Chrome Molybdenum steel with Manganese phosphating.

LOCK PIN

It provides greater hold in comparison to a locking grain.

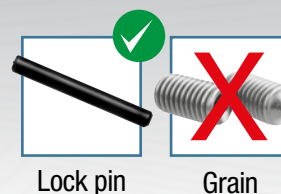

Lock pin

Grain

ISO 9227

Modular with the drawers of
USAG roller cabinets



235 1/2" M/C16

Code U02359285



16
PIECES

1 1/2"

Assortment with **IMPACT** hexagonal sockets in modular box

DESCRIPTION	ITEM/SIZE	PCS.
Impact hexagonal sockets	235 1/2 M 10-12-13-14-15-16-17-18-19-21-22-24-27-30-32 mm	15
Lock pins	235 MCA/4-6	2
Safety rings	235 MDA/4-6	2
Impact extensions	236 1/2 M/125	1



Modular with the drawers of
USAG roller cabinets



235 3/4" M/C8

Code U02359286



8
PIECES

3/4"

Assortment with short hexagonal impact sockets

DESCRIPTION	ITEM/SIZE	PCS.
Impact hexagonal sockets	235 3/4" M 21-22-24-27-30-32-36-41 mm	8

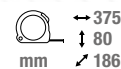

NEW

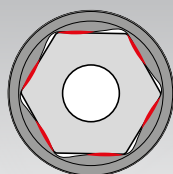

ISO 2725-2
ISO 1174-2

Range of hexagonal **IMPACT** sockets

IMPROVED PROFILE

Greater contact between the socket and the flat surface of nut or screw.

PHOSPHATIZED FINISH

ISO 9227

LASER MARKING

Logo and size more visible (sizes 1" and 1 1/2" by engraving).

SPECIAL STEEL

Chrome Molybdenum for higher impact resistance.

IMPACT SOCKETS 235 MB COMPACT DIMENSIONS, RESISTANCE GUARANTEED



ISO 1174-2
ISO 691



**IDEAL FOR
COMPACT
IMPACT
WRENCHES**

25% SHORTER

Same performance of a standard impact socket 235 1/2 M.



235 1/2" MB/C10
Code U02350530



**10
PIECES**

**1
2**"

Assortment with short hexagonal impact sockets

DESCRIPTION	ITEM/SIZE	PCS.
Short impact hexagonal sockets	235 1/2" M 10-11-12-13-14-15-16-17-18-19	10

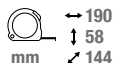

DETAIL OF THE SOCKETS INCLUDED:

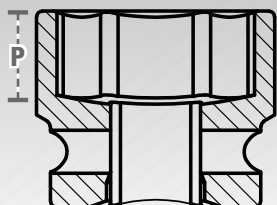

SIZE	Ø EXTERNAL	LENGTH	P	SIZE	Ø EXTERNAL	LENGTH	P
10	17 mm	28 mm	4 mm	15	23 mm	28 mm	5 mm
11	18 mm	28 mm	5 mm	16	24 mm	28 mm	5 mm
12	19 mm	28 mm	5 mm	17	26 mm	28 mm	8 mm
13	20 mm	28 mm	5 mm	18	28 mm	28 mm	8 mm
14	22 mm	28 mm	5 mm	19	28 mm	28 mm	8 mm

USE WITH RATCHET OR IMPACT WRENCH

236 K for sockets



YouTube

GREAT ACCESSIBILITY
HEAD DIMENSIONS AS A RATCHET*:



39 mm

*Comparison with 1/2" ratchet.

236 K

Chain extension in Aluminium for sockets

CODE	□	L	H	📦
U02360700	1/2"	340 mm	39 mm	1,1 kg
U02360698	1/4"	260 mm	27 mm	300 g

1/2"

1/4"



YouTube

236 KE for bits

MINIMUM SIZE
DIRECT COUPLING FOR
IMPACT BITS.



Integrated spring steel ring.

236 KE

Bit-holder chain extension in Aluminium

CODE	□	◇	L	H	📦
U02360705	1/2"	1/2"	340 mm	24 mm	1,1 kg
U02360710	1/4"	1/4"	260 mm	19 mm	300 g

1/2"

1/4"



CONTAINS THE NEW SHORT IMPACT SOCKETS 235 1/2" MB



236 KE/C22
Code U02360900

Assortment with short hexagonal impact sockets, extension wrench and impact bits

DESCRIPTION	ITEM/SIZE	PCS.
Short impact hexagonal sockets	235 1/2" MB 13-14-15-16-17-18-19	7
Bit-holder chain extension in Aluminium	236 KE 1/2"	1
Impact bits for hexagonal screws - 1/2" connection	687 E 5-6-8-10-12-14	6
Impact bits for TORX® screws - 1/2" connection	687 TX T25-T27-T30-T40-T45-T50-T55	7
Adapter for impact sockets	236 KEADP	1

mm
↔ 415
↓ 92
↗ 283

1/2"

22
PIECES

THE COMPLETE CATALOG AT YOUR FINGERTIPS, ALWAYS UPDATED



Download the App!

- Works offline.
- Push notifications.
- Light.



ON SMARTPHONE AND TABLET

Do you need support from us?
Go to our website:



usag.it/en/contacts/support



Promotion valid till 31/03/2023 while stocks last.

The images shown in this catalogue are not binding.

Stanley Black & Decker italia S.r.l. reserves the right to change the technical characteristics of its products at any time.

U63000529Y

RESELLERS' STAMP

Stanley Black & Decker Italia S.r.l.
Via Volta, 3 - 21020 Monvalle (VA)
Tel. +39 0332 790111
info.mv@usag.it

usag-tools.net

